

-150V P-Channel Enhancement Mode MOSFET

Description

The AP7P15Y uses advanced trench technology to provide excellent $R_{DS(ON)}$, low gate charge and operation with gate voltages as low as 4.5V. This device is suitable for use as a Battery protection or in other Switching application.

General Features

$V_{DS} = -150V$ $I_D = -7A$

$R_{DS(ON)} < 780m\Omega$ @ $V_{GS}=10V$ (Type: **620mΩ**)

Application

Brushless motor

Load switch

Uninterruptible power supply

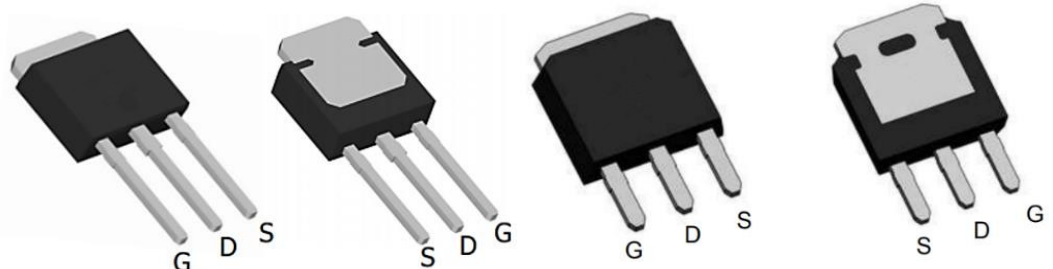
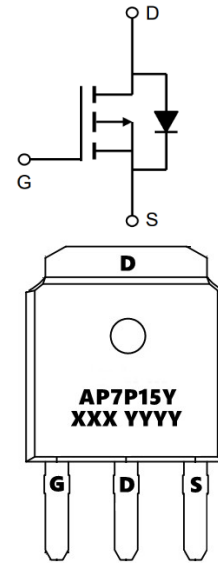

Package Marking and Ordering Information

Product ID	Pack	Marking	Qty(PCS)
AP7P15Y	TO-251L-3L	AP13P06Y XXXX YYYY	4000
AP7P15Y	TO-251S-3L	AP13P06Y XXXX YYYY	4000

Absolute Maximum Ratings ($T_C=25^\circ C$ unless otherwise noted)

Symbol	Parameter	Rating	Units
V_{DS}	Drain-Source Voltage	-150	V
V_{GS}	Gate-Source Voltage	± 20	V
$I_{D@T_A=25^\circ C}$	Continuous Drain Current, $-V_{GS}$ @ $-10V^1$	-7.0	A
$I_{D@T_A=70^\circ C}$	Continuous Drain Current, $-V_{GS}$ @ $-10V^1$	-4.8	A
IDM	Pulsed Drain Current ²	-28	A
EAS	Single Pulse Avalanche Energy ³	56.5	mJ
IAS	Avalanche Current	5	A
$P_D@T_A=25^\circ C$	Total Power Dissipation ⁴	2	W
TSTG	Storage Temperature Range	-55 to 150	$^\circ C$
T_J	Operating Junction Temperature Range	-55 to 150	$^\circ C$
$R_{\theta JA}$	Thermal Resistance Junction-Ambient ¹	62	$^\circ C/W$
$R_{\theta JC}$	Thermal Resistance Junction-Case ¹	40	$^\circ C/W$

-150V P-Channel Enhancement Mode MOSFET

P-Channel Electrical Characteristics (T_J =25 °C, unless otherwise noted)

Symbol	Parameter	Conditions	Min.	Typ.	Max.	Unit
BVDSS	Drain-Source Breakdown Voltage	VGS=0V , ID=-250uA	-150	-168	---	V
RDS(ON)	Static Drain-Source On-Resistance	VGS=-10V , ID=-1A	---	620	780	mΩ
RDS(ON)	Static Drain-Source On-Resistance	VGS=-6V , ID=-0.5A	---	700	980	
VGS(th)	Gate Threshold Voltage	VGS=VDS , ID =-250uA	-2.0	-3.0	-4.0	V
IDSS	Drain-Source Leakage Current	VDS=120V ,VGS=0V ,TJ=25°C	---	---	1	uA
IDSS	Drain-Source Leakage Current	VDS=120V ,VGS=0V ,TJ=85°C	---	---	30	uA
IGSS	Gate-Source Leakage Current	VGS=±20V , VDS=0V	---	---	±100	nA
Rg	Gate Resistance	VDS=0V , VGS=0V , f=1MHz	---	12	---	Ω
Qg	Total Gate Charge	VDS=-75V , VGS=-10V , ID=-1A	---	10.8	---	nC
Qgs	Gate-Source Charge		---	3.1	---	nC
Qgd	Gate-Drain Charge		---	2.2	---	nC
Td(on)	Turn-On Delay Time	VDD=-30V , VGS=-10V , RG=6Ω, ID=-1A	---	21	---	ns
Tr	Rise Time		---	16	---	ns
Td(off)	Turn-Off Delay Time		---	40	---	ns
Tf	Fall Time		---	18	---	ns
Ciss	Input Capacitance	VDS=-75V , VGS=0V , f=1MHz	---	706	---	pF
Coss	Output Capacitance		---	23	---	pF
Crss	Reverse Transfer Capacitance		---	13	---	pF

Note :

- 1、 The data tested by surface mounted on a 1 inch 2 FR-4 board with 2OZ copper.
- 2、 The data tested by pulsed , pulse width \leq 300us , duty cycle \leq 2%
- 3、 The EAS data shows Max. rating . The test condition is VDD =-50V,VGS =-10V,L=0.5mH,IAS =-5A
- 4、 The power dissipation is limited by 150°C junction temperature
- 5、 The data is theoretically the same as I D and I DM , in real applications , should be limited by total power dissipation.

-150V P-Channel Enhancement Mode MOSFET

Typical Characteristics

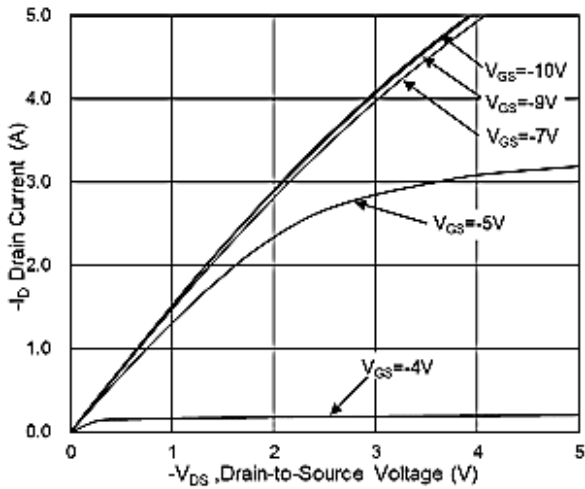

Fig.1 Typical Output Characteristics

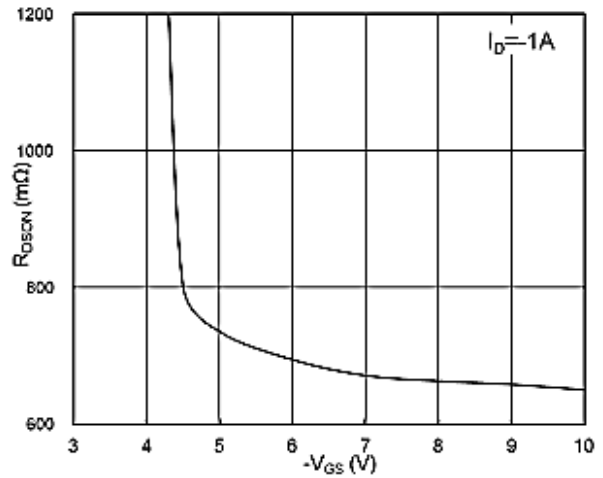

Fig.2 On-Resistance vs G-S Voltage

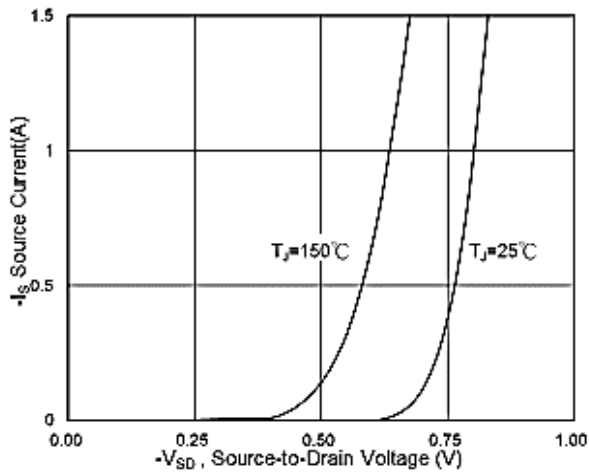

Fig.3 Source Drain Forward Characteristics

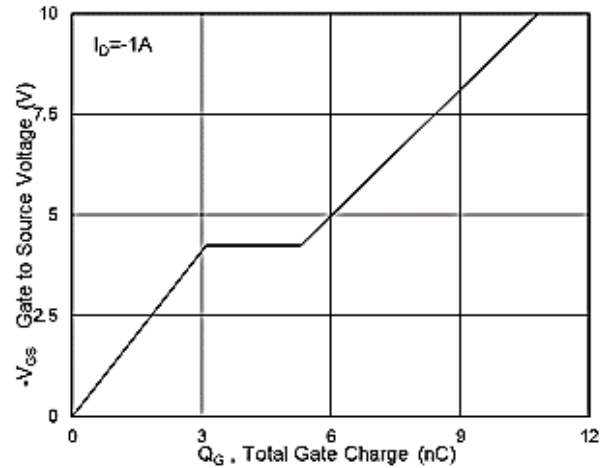

Fig.4 Gate-Charge Characteristics

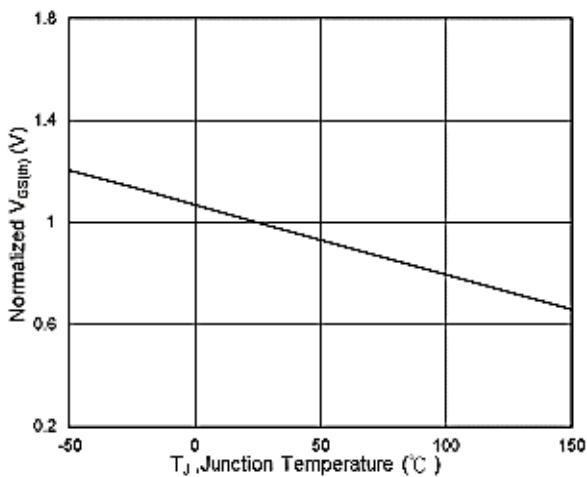

Fig.5 Normalized $V_{GS(th)}$ vs T_J

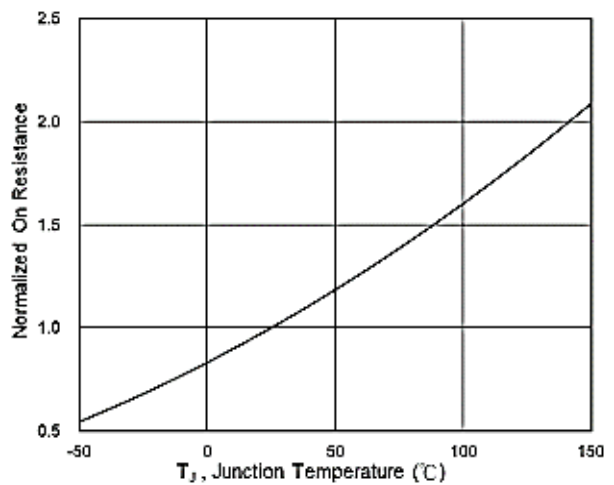

Fig.6 Normalized $R_{DS(on)}$ vs T_J

-150V P-Channel Enhancement Mode MOSFET

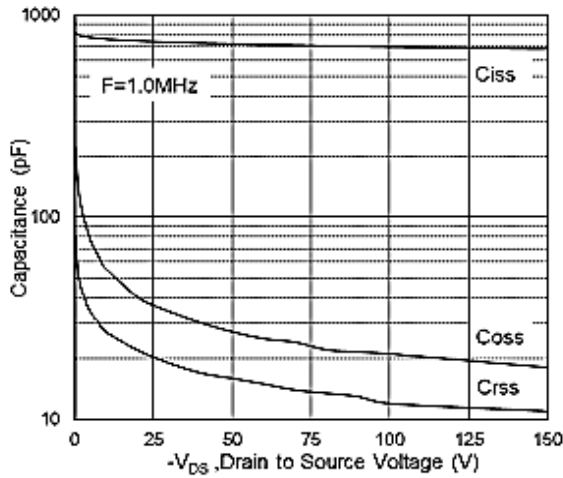

Fig.7 Capacitance

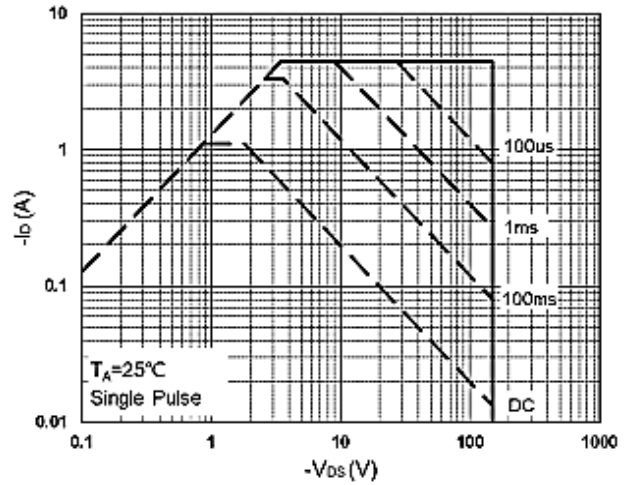

Fig.8 Safe Operating Area

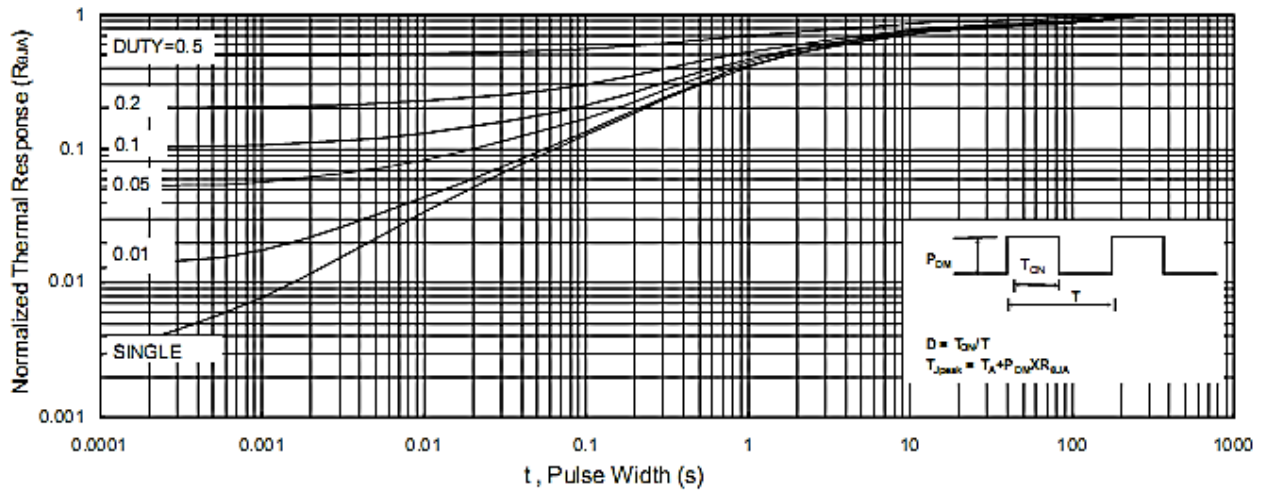

Fig.9 Normalized Maximum Transient Thermal Impedance

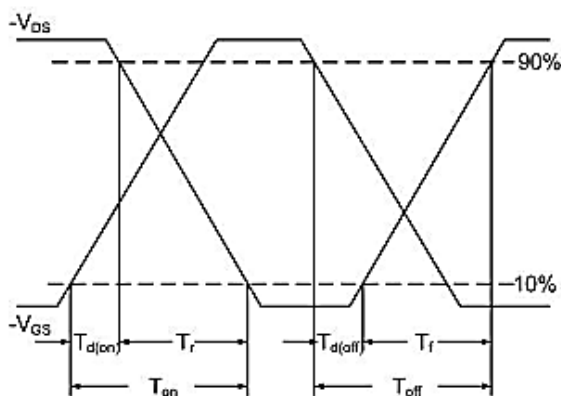

Fig.10 Switching Time Waveform

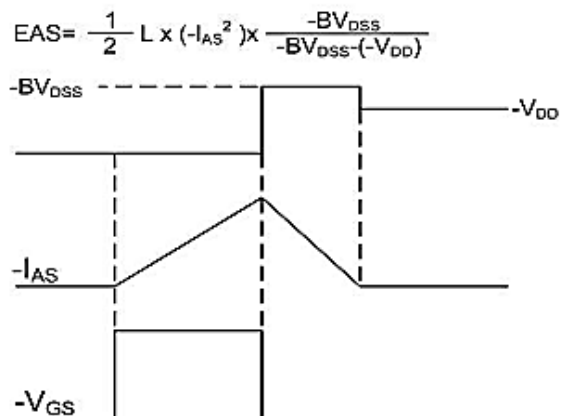
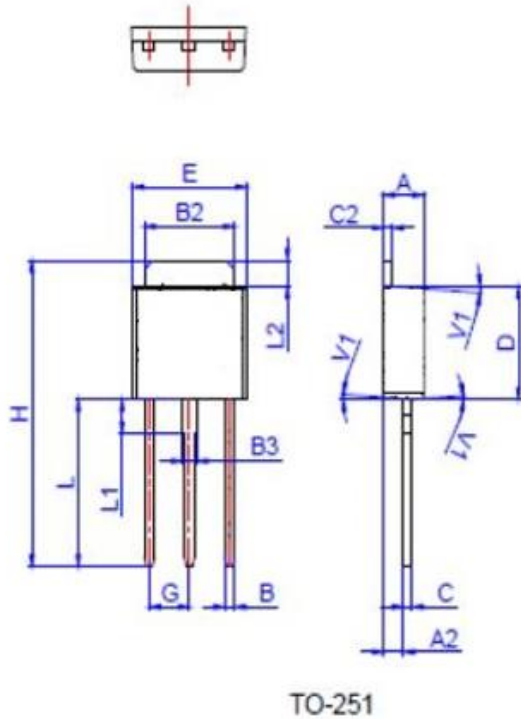

Fig.11 Unclamped Inductive Waveform

Package Mechanical Data-TO-251L-3L

Ref.	Dimensions					
	Millimeters			Inches		
	Min.	Typ.	Max.	Min.	Typ.	Max.
A	2.20		2.40	0.086		0.095
A2	0.90		1.20	0.035		0.047
B	0.55		0.65	0.022		0.026
B2	5.10		5.40	0.200		0.213
B3	0.76		0.85	0.030		0.033
C	0.45		0.62	0.018		0.024
C2	0.48		0.62	0.019		0.024
D	6.00		6.20	0.236		0.244
E	6.40		6.70	0.252		0.264
G		2.30			0.091	
H	16.0		17.0	0.630		0.669
L	8.90		9.40	0.350		0.370
L1	1.80		1.90	0.071		0.075
L2	1.37		1.50	0.054		0.059
V1		4°			4°	

Package Information -TO-251

OUTLINE	TUBE (PCS)	INNER BOX (PCS)	PER CARTON (PCS)
TUBE	80	4,000	32,000

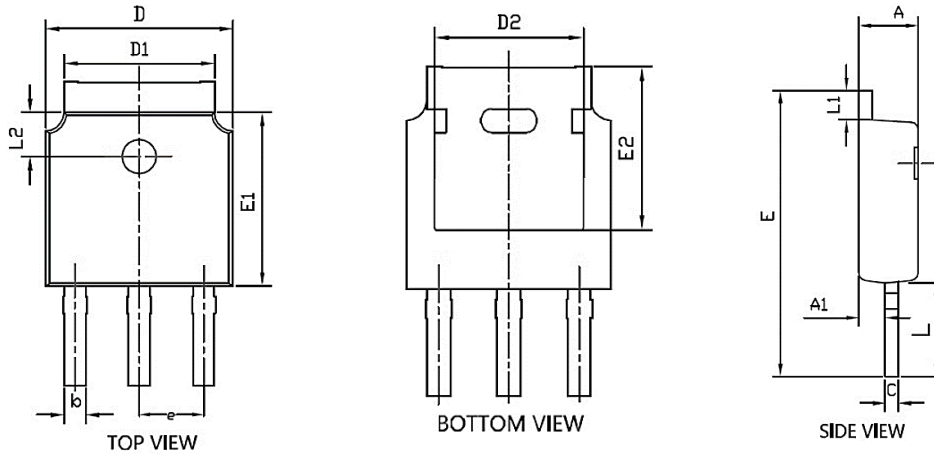
Package Mechanical Data-TO-251S-3L

Symbol	Common		
	mm		
	Mim	Nom	Max
A	2.2	2.3	2.4
A1	0.9	1.0	1.1
b	0.66	0.76	0.86
C	0.46	0.52	0.58
D	6.50	6.6	6.7
D1	5.15	5.3	5.45
D2	4.6	4.8	4.95
E	10.4	----	11.5
E1	6.0	6.1	6.2
E2	5.400REF		
e	2.286BSC		
L	3.5	4.0	4.3
L1	0.9	---	1.27
L2	1.4	---	1.9