

500V N-Channel Enhancement Mode MOSFET

Description

The AP13N50F/P is silicon N-channel Enhanced VDMOSFETs, is obtained by the self-aligned planar Technology which reduce the conduction loss, improve switching performance and enhance the avalanche energy. The transistor can be used in various power switching circuit for system miniaturization and higher efficiency.

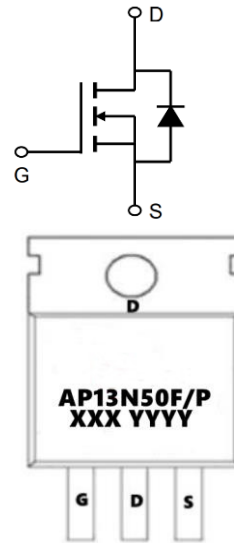

General Features

$V_{DS} = 500V$ $I_D = 13A$

$R_{DS(ON)} < 500m\Omega$ @ $V_{GS}=10V$ (Type: 420m Ω)

Application

Uninterruptible Power Supply(UPS)

Power Factor Correction (PFC)

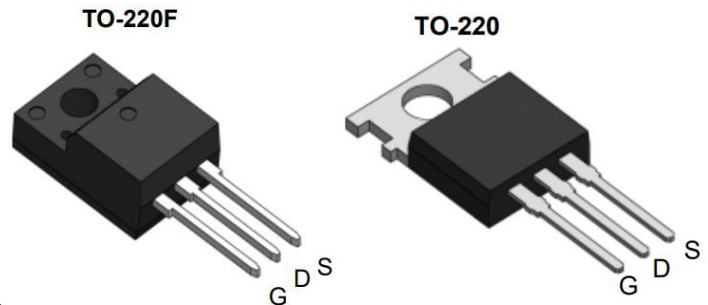

Package Marking and Ordering Information

Product ID	Pack	Marking	Qty(PCS)
AP13N50F	TO-220F-3L	AP13N50F XXX YYYY	1000
AP13N50P	TO-220-3L	AP13N50P XXX YYYY	1000

Absolute Maximum Ratings ($T_C=25^\circ C$ unless otherwise noted)

Symbol	Parameter	Value		Unit
		TO-220F	TO-220	
V_{DSS}	Drain-Source Voltage ($V_{GS} = 0V$)	500		V
I_D	Continuous Drain Current	13		A
I_{DM}	Pulsed Drain Current (note1)	52		A
V_{GS}	Gate-Source Voltage	± 30		V
E_{AS}	Single Pulse Avalanche Energy (note2)	400		mJ
I_{AR}	Avalanche Current (note1)	13		A
E_{AR}	Repetitive Avalanche Energy note1)	57		mJ
P_D	Power Dissipation ($T_C = 25^\circ C$)	31		W
T_J, T_{stg}	Operating Junction and Storage Temperature Range	-55~+150		$^\circ C$
R_{thJC}	Thermal Resistance, Junction-to-Case	3.92		$^\circ C/W$
R_{thJA}	Thermal Resistance, Junction-to-Ambient	62.5		$^\circ C/W$



500V N-Channel Enhancement Mode MOSFET

Electrical Characteristics (T_J=25°C, unless otherwise noted)

Symbol	Parameter	Test Conditions	Min	Typ	Max	Units
BVDSS	Drain-Source Breakdown Voltage	VGS=0V, ID=250μA	500			V
ΔBVDSS/ ΔTJ	Breakdown Voltage Temperature Coefficient	ID = 250 μA, Referenced to 25°C		0.52		V/°C
IDSS	Zero Gate Voltage Drain Current	VDS=500V, VGS=0V			1	μA
		VDS=400V, TC=125°C			10	μA
IGSSF	Gate-Body Leakage Current, Forward	VGS=30V, VDS=0V			100	nA
IGSSR	Gate-Body Leakage Current, Reverse	VGS=-30V, VDS=0V			-100	nA
VGS(TH)	Gate Threshold voltage	VDS=VGS, ID =250 uA	2.0		4.0	V
RDS(On)	Drain-Source on-state resistance	VGS=10V, ID=6.5A, T _J =25°C		420	500	mΩ
gFS	Forward Transconductance	VDS=40V, ID=6.5A (Note 4)		12.0		S
Ciss	Input capacitance	VDS=25V, VGS=0V, f=1.0 MHz		1175		pF
Coss	Output capacitance			176		pF
Crss	Reverse transfer capacitance			6		pF
td(on)	Turn On Delay Time	VDD = 250 V, ID = 13 A, RG = 25 Ω (Note 4, 5)		26		ns
tr	Rising Time			39		ns
td(off)	Turn Off Delay Time			87		ns
tf	Fall Time			42		ns
Qg	Total Gate Charge	VDS = 400 V, ID = 13 A, VGS = 10 V (Note 4, 5)		22		nC
Qgs	Gate-Source Charge			6.4		nC
Qgd	Gate-Drain Charge			6.8		nC
ISM	Maximum Pulsed Drain-Source Diode Forward Current				52	A
VSD	Diode Forward Voltage	VGS= 0 V, IS = 13 A			1.2	V
trr	Reverse Recovery Time	VGS = 0 V, IS = 13 A, dIF / dt = 100 A/μs Note 4)		334		ns
Qrr	Reverse Recovery Charge			2.6		μC

Note :

- 1、 The data tested by surface mounted on a 1 inch² FR-4 board with 2OZ copper.
- 2、 The EAS data shows Max. rating . L=4.1Mh IAS=16A, VDD=50V, RG=25Ω, Starting T_J = 25 °C
- 3、 The test condition is Pulse Test: Pulse width ≤ 300μs, Duty Cycle ≤ 1%
- 4、 The power dissipation is limited by 150°C junction temperature
- 5、 The data is theoretically the same as ID and IDM , in real applications , should be limited by total power dissipation.

500V N-Channel Enhancement Mode MOSFET

Typical Characteristics

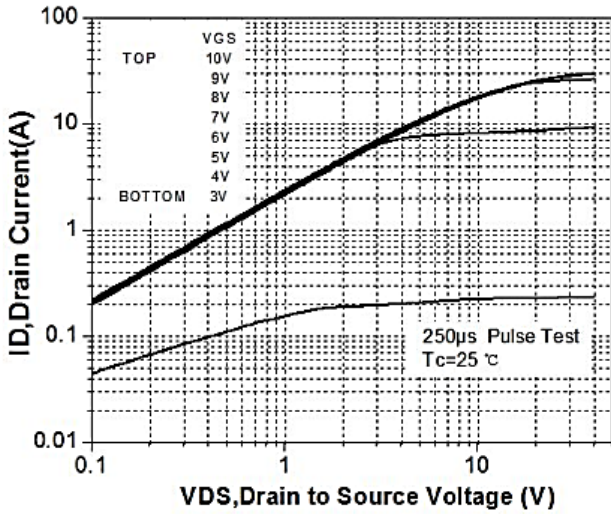

Figure 1. On-Region Characteristics

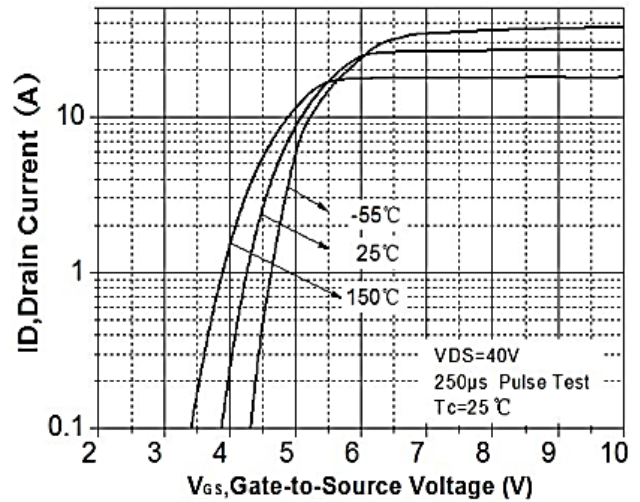

Figure 2. Transfer Characteristics

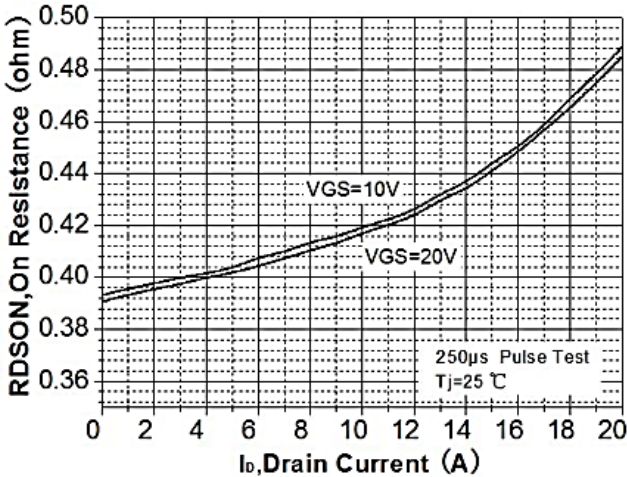

Figure 3. On-Resistance Variation vs Drain Current and Gate Voltage

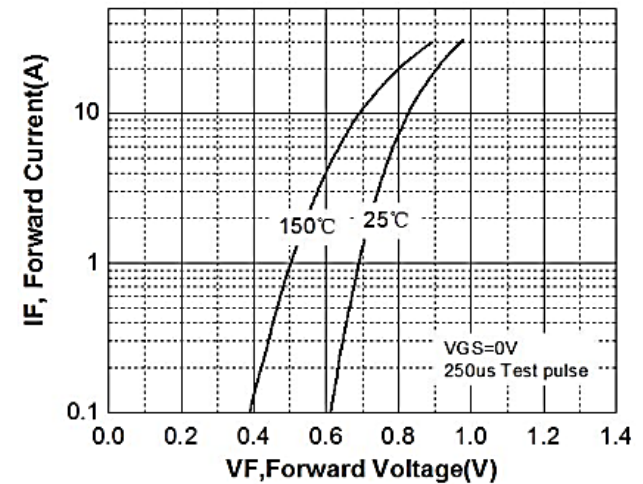

Figure 4. Body Diode Forward Voltage Variation with Source Current and Temperature

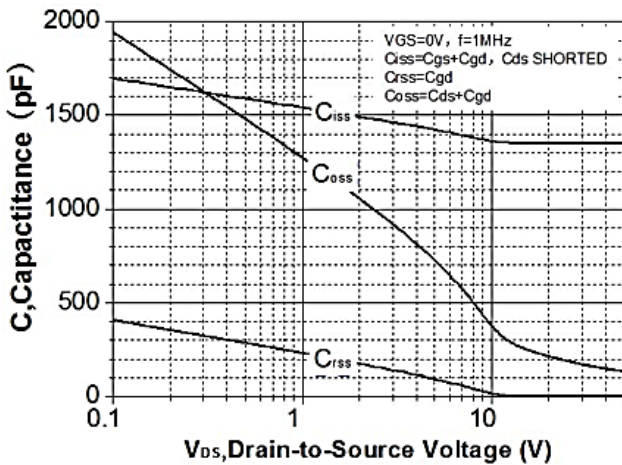

Figure 5. Capacitance Characteristics

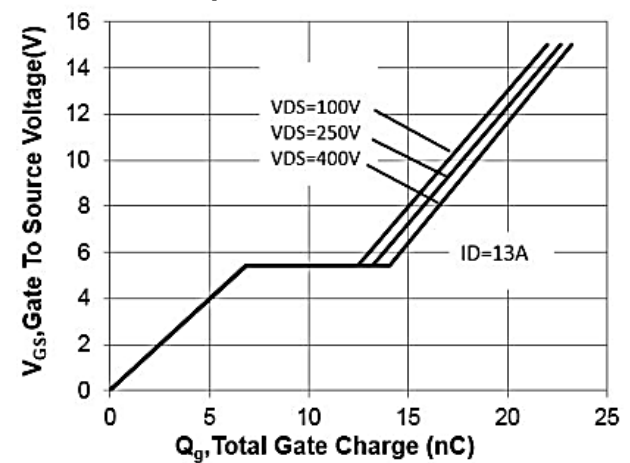

Figure 6. Gate Charge Characteristics

500V N-Channel Enhancement Mode MOSFET

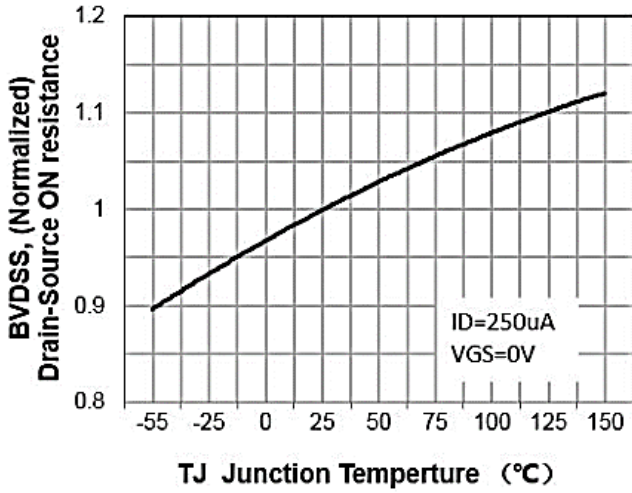

Figure 7. Breakdown Voltage Variation vs Temperature

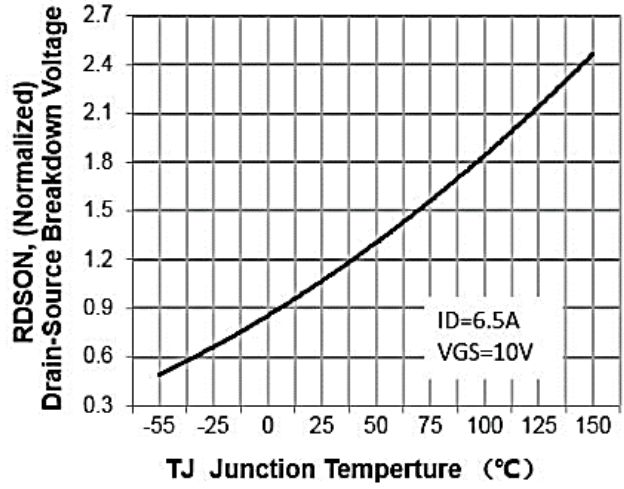

Figure 8. On-Resistance Variation vs Temperature

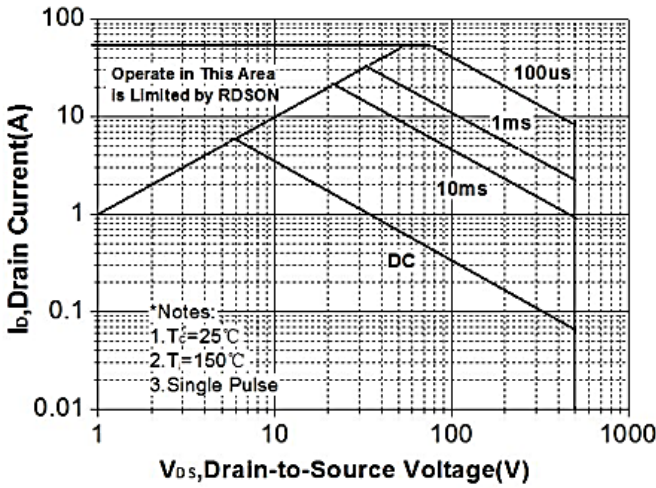

Figure 9. Maximum Safe Operating Area

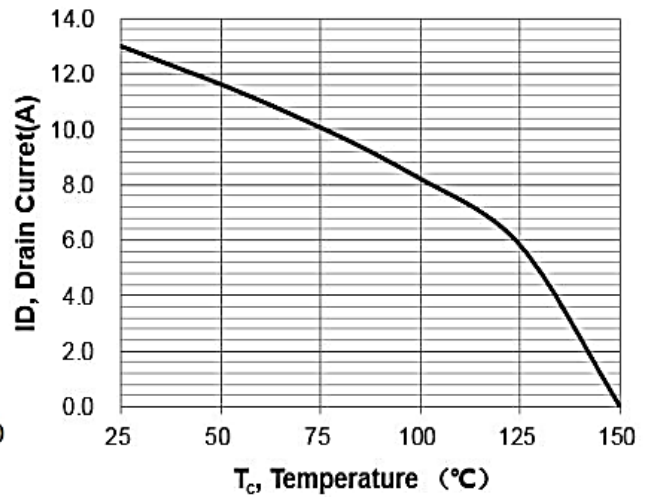

Figure 10. Maximum Drain Current vs Case Temperature

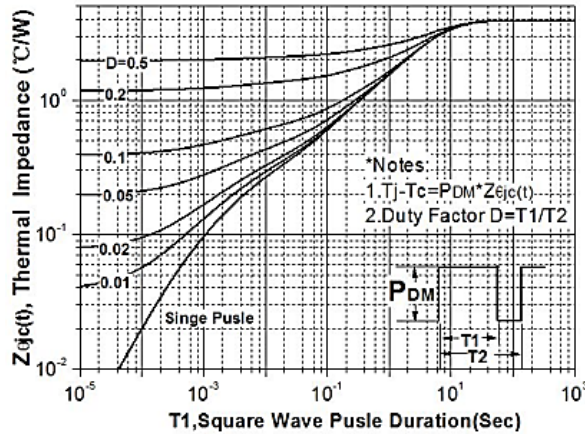
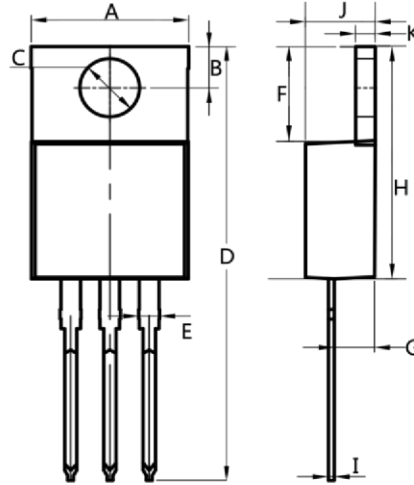

Figure 11. Transient Thermal Response Curve

500V N-Channel Enhancement Mode MOSFET

TO-220AB



Dim.	Min.	Max.
A	10.0	10.4
B	2.5	3.0
C	3.5	4.0
D	28.0	30.0
E	1.1	1.5
F	6.2	6.6
G	2.9	3.3
H	15.0	16.0
I	0.35	0.45
J	4.3	4.7
K	1.2	1.4

All Dimensions in millimeter

ITO-220AB

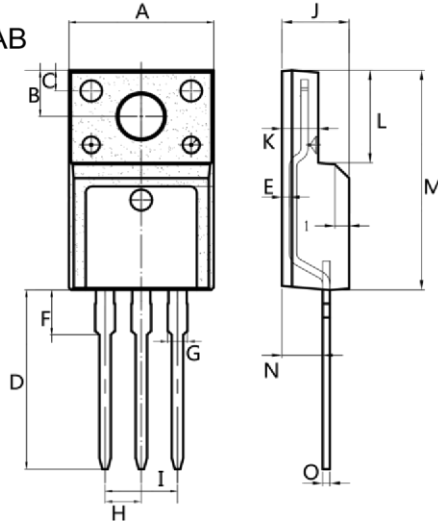

Dim.	Min.	Max.
A	9.9	10.3
B	2.9	3.5
C	1.15	1.45
D	12.75	13.25
E	0.55	0.75
F	3.1	3.5
G	1.25	1.45
H	Typ 2.54	
I	Typ 5.08	
J	4.55	4.75
K	2.4	2.7
L	6.35	6.75
M	15.0	16.0
N	2.75	3.15
O	0.45	0.60

All Dimensions in millimeter

TO-263

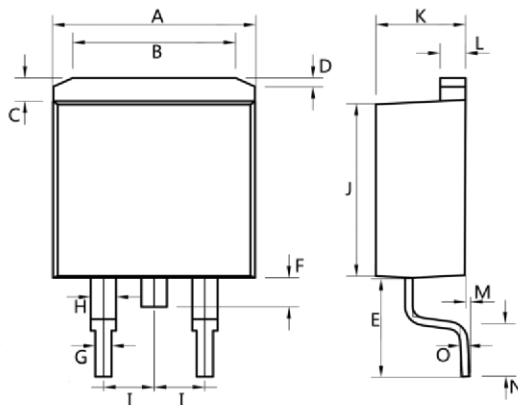

Dim.	Min.	Max.
A	10.0	10.5
B	7.25	7.75
C	1.3	1.5
D	0.55	0.75
E	5.0	6.0
F	1.4	1.6
G	0.75	0.95
H	1.15	1.35
I	Typ 2.54	
J	8.4	8.6
K	4.4	4.6
L	1.25	1.45
M	0.02	0.1
N	2.4	2.8
O	0.35	0.45

All Dimensions in millimeter