

## 120V N-Channel Enhancement Mode MOSFET

### Description

The AP15N12D uses advanced trench technology to provide excellent  $R_{DS(ON)}$ , low gate charge and operation with gate voltages as low as 4.5V. This device is suitable for use as a Battery protection or in other Switching application.

### General Features

$V_{DS} = 120V$   $I_D = 15A$

$R_{DS(ON)} < 150m\Omega @ V_{GS}=10V$  (Type: 100m $\Omega$ )

### Application

Automotive lighting

Load switch

Uninterruptible power supply

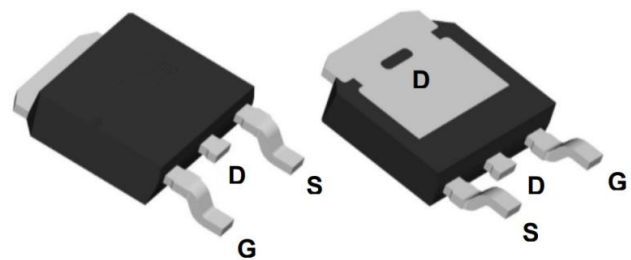
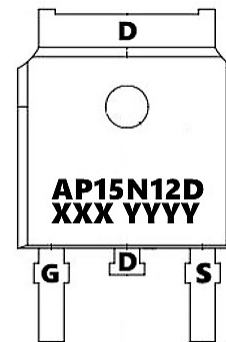
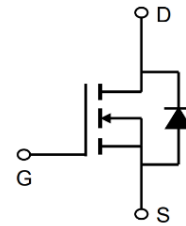

### Package Marking and Ordering Information

Product ID	Pack	Marking	Qty(PCS)
AP15N12D	TO-252-3L	AP15N12D XXX YYYY	2500

### Absolute Maximum Ratings (TC=25°C unless otherwise noted)

Symbol	Parameter	Rating	Units
V <sub>DS</sub>	Drain-Source Voltage	120	V
V <sub>GS</sub>	Gate-Source Voltage	±20	V
I <sub>D</sub> @T <sub>C</sub> =25°C	Drain Current, V <sub>GS</sub> @ 10V	15	A
I <sub>D</sub> @T <sub>C</sub> =100°C	Drain Current, V <sub>GS</sub> @ 10V	7.5	A
IDM	Pulsed Drain Current <sup>1</sup>	45	A
P <sub>D</sub> @T <sub>C</sub> =25°C	Total Power Dissipation	30	W
P <sub>D</sub> @T <sub>A</sub> =25°C	Total Power Dissipation <sup>3</sup>	2.7	W
TSTG	Storage Temperature Range	-55 to 150	°C
T <sub>J</sub>	Operating Junction Temperature Range	-55 to 150	°C
R $\theta$ JA	Maximum Thermal Resistance, Junctionambient	62.5	°C/W
R $\theta$ JC	Maximum Thermal Resistance, Junction-case	5.1	°C/W

## 120V N-Channel Enhancement Mode MOSFET

### Electrical Characteristics@T<sub>J</sub>=25°C(unless otherwise specified)

Symbol	Parameter	Test Condition	Min.	Typ.	Max.	Units
V(BR)DSS	Drain-Source Breakdown Voltage	VGS=0V, ID=250μA	120	135	-	V
IDSS	Zero Gate Voltage Drain Current	VDS=100V, VGS=0V,	-	-	1.0	μA
IGSS	Gate to Body Leakage Current	VDS=0V, VGS=±20V	-	-	±100	nA
VGS(th)	Gate Threshold Voltage	VDS=VGS, ID=250μA	1.2	2.0	2.5	V
RDS(on)	Static Drain-Source on-Resistance note3	VGS=10V, ID=5A	-	100	150	mΩ
		VGS=4.5V, ID=3A	-	120	180	mΩ
g fs	Forward Transconductance	VDS =5V , ID =5A		14		S
RG	Gate Resistance	VDS = 0V, VGS =0V,f =1MHz		3		Ω
Ciss	Input Capacitance	VDS=15V, VGS=0V, f=1.0MHz	-	1100	-	pF
Coss	Output Capacitance		-	55	-	pF
Crss	Reverse Transfer Capacitance		-	40	-	pF
Qg	Total Gate Charge	VDS=50V, ID=5A, VGS=10V	-	11.9	-	nC
Qgs	Gate-Source Charge		-	2.8	-	nC
Qgd	Gate-Drain("Miller") Charge		-	1.7	-	nC
td(on)	Turn-on Delay Time	VDS=30V, ID=5A, RG=1.8Ω, VGS=10V	-	3.8	-	ns
tr	Turn-on Rise Time		-	25.8	-	ns
td(off)	Turn-off Delay Time		-	16	-	ns
tf	Turn-off Fall Time		-	8.8	-	ns
IS	Continuous Source Current1,5	VG=VD=0V , Force Current	-	-	14.6	A
ISM	Pulsed Source Current2,5		-	-	25	A
VSD	Diode Forward Voltage2	VGS=0V, IS=10A	-	-	1.2	V

#### Note :

- The data tested by surface mounted on a 1 inch 2 FR-4 board with 2OZ copper.
- The EAS data shows Max. rating . The test condition is T<sub>J</sub>=25°C, V<sub>DD</sub>=72V, V<sub>G</sub>=10V, L=0.1mH, R<sub>g</sub>=25Ω, I<sub>AS</sub>=8A
- The data tested by pulsed , pulse width ≤ 300us , duty cycle ≤ 2%
- The power dissipation is limited by 150°C junction temperature
- The data is theoretically the same as I<sub>D</sub> and I<sub>DM</sub> , in real applications , should be limited by total power dissipation.

**120V N-Channel Enhancement Mode MOSFET**

**Typical Characteristics**

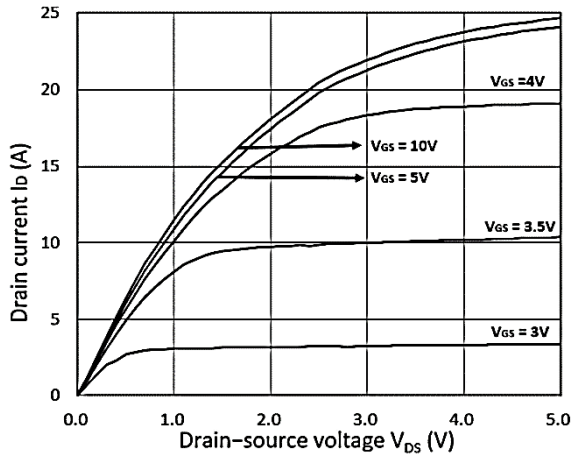

**Figure 1. Output Characteristics**

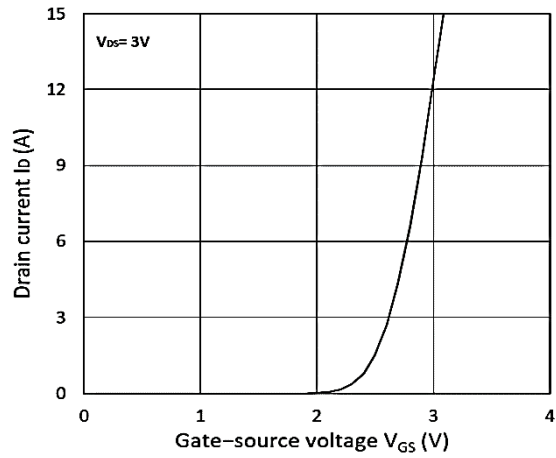

**Figure 2. Transfer Characteristics**

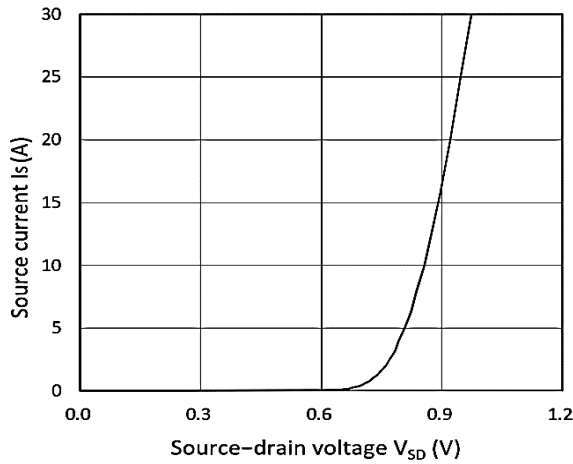

**Figure 3. Forward Characteristics of Reverse**

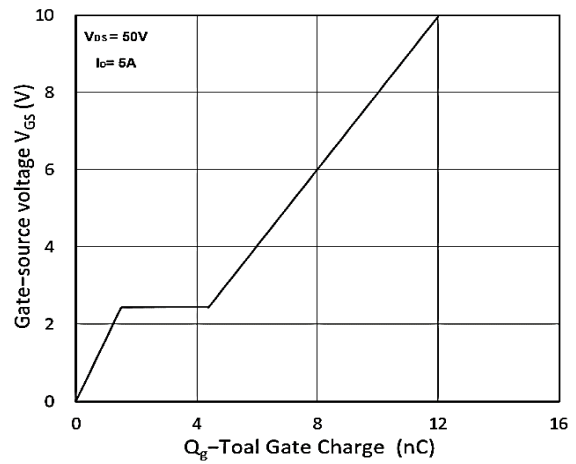

**Figure 4. Gate Charge Characteristics**

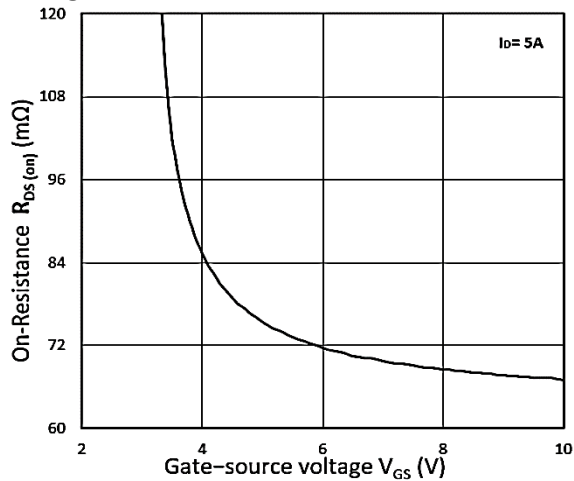

**Figure 5.  $R_{DS(on)}$  vs.  $V_{GS}$**

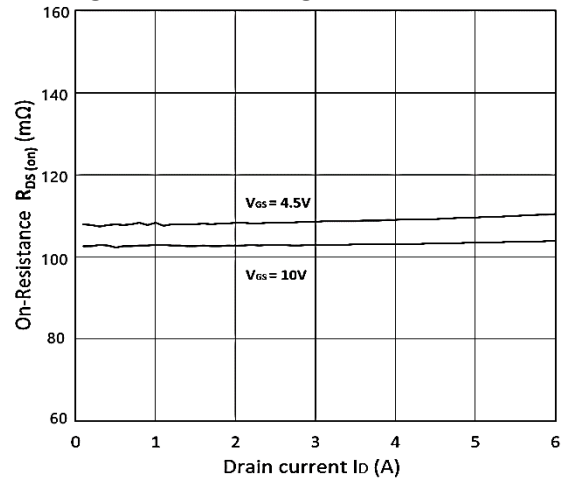

**Figure 6.  $R_{DS(on)}$  vs.  $I_D$**

**120V N-Channel Enhancement Mode MOSFET**

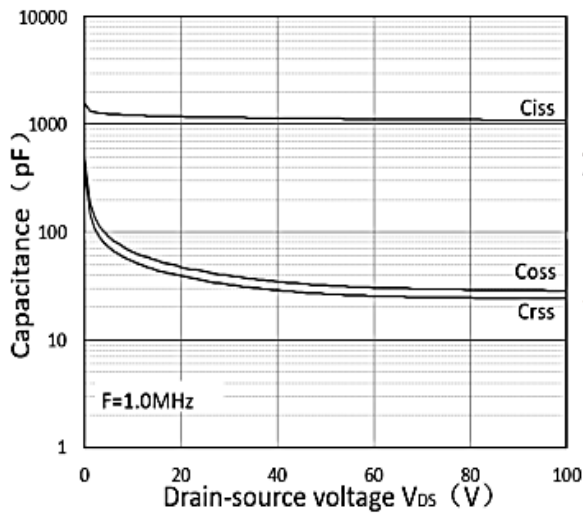

Figure 7. Capacitance Characteristics

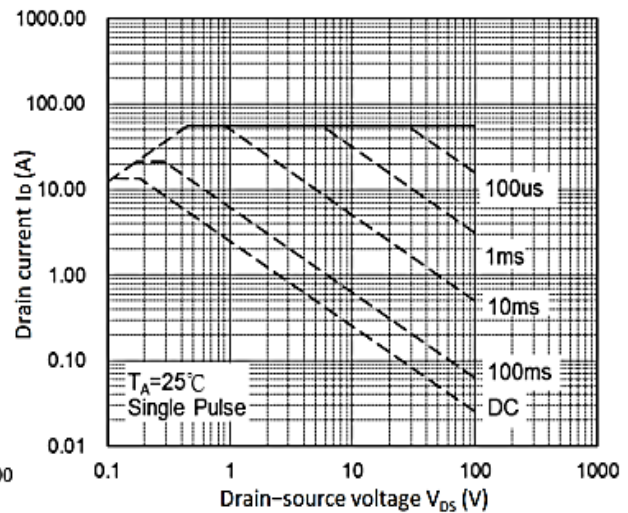

Figure 8. Safe Operating Area

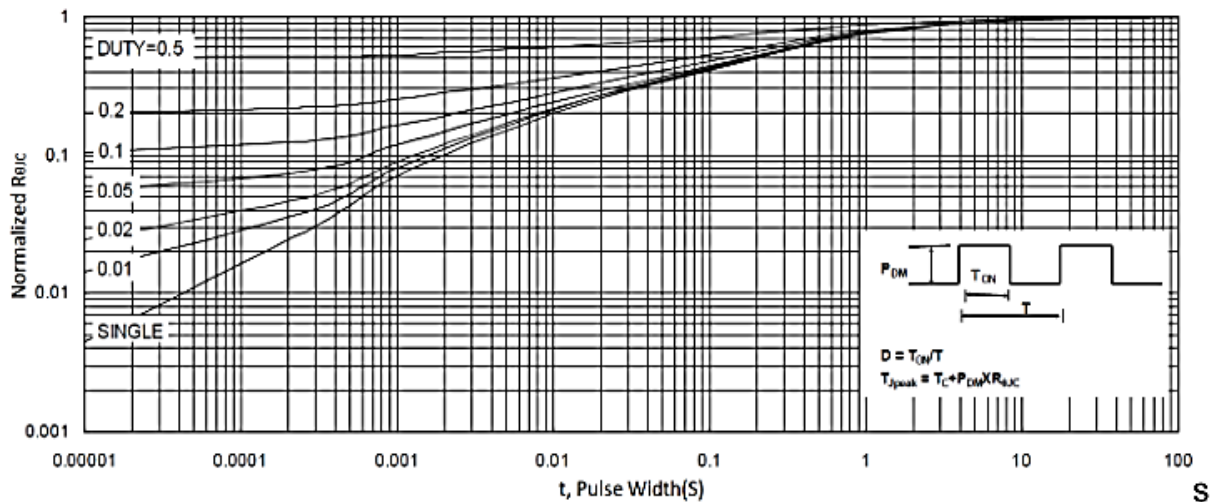

Figure 9. Normalized Maximum Transient Thermal Impedance

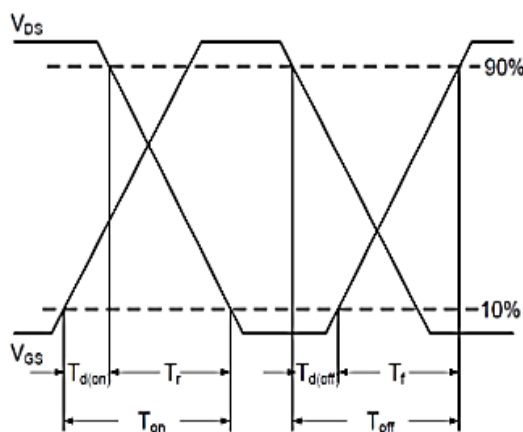

Figure 10. Switching Time Waveform

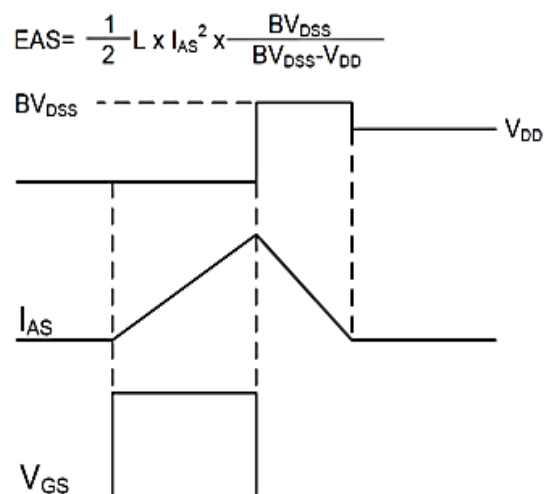
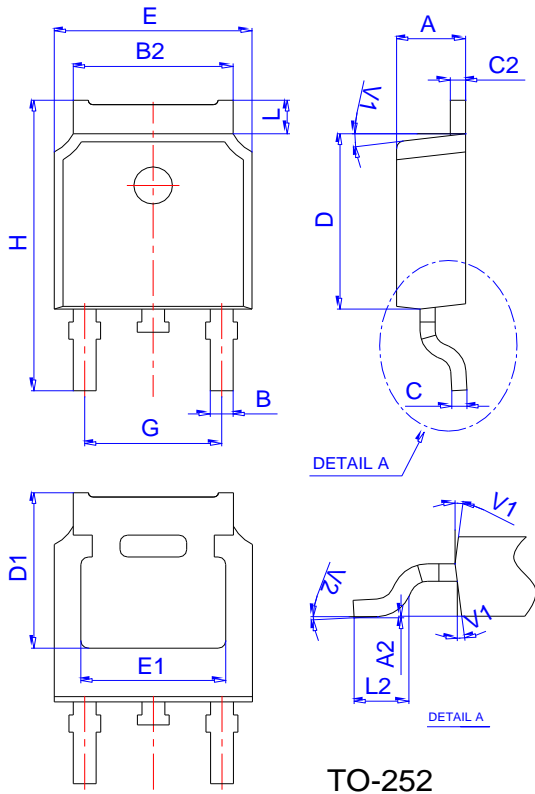

Figure 11. Unclamped Inductive Switching Waveform



## 120V N-Channel Enhancement Mode MOSFET

### Package Mechanical Data: TO-252-3L



Ref.	Dimensions					
	Millimeters			Inches		
	Min.	Typ.	Max.	Min.	Typ.	Max.
A	2.10		2.50	0.083		0.098
A2	0		0.10	0		0.004
B	0.66		0.86	0.026		0.034
B2	5.18		5.48	0.202		0.216
C	0.40		0.60	0.016		0.024
C2	0.44		0.58	0.017		0.023
D	5.90		6.30	0.232		0.248
D1	5.30REF			0.209REF		
E	6.40		6.80	0.252		0.268
E1	4.63			0.182		
G	4.47		4.67	0.176		0.184
H	9.50		10.70	0.374		0.421
L	1.09		1.21	0.043		0.048
L2	1.35		1.65	0.053		0.065
V1		7°			7°	
V2	0°		6°	0°		6°

### Reel Specification-TO-252

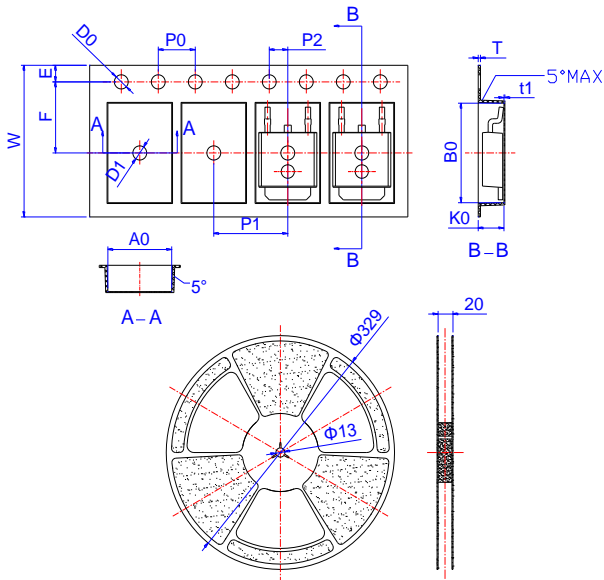

Ref.	Dimensions					
	Millimeters			Inches		
	Min.	Typ.	Max.	Min.	Typ.	Max.
W	15.90	16.00	16.10	0.626	0.630	0.634
E	1.65	1.75	1.85	0.065	0.069	0.073
F	7.40	7.50	7.60	0.291	0.295	0.299
D0	1.40	1.50	1.60	0.055	0.059	0.063
D1	1.40	1.50	1.60	0.055	0.059	0.063
P0	3.90	4.00	4.10	0.154	0.157	0.161
P1	7.90	8.00	8.10	0.311	0.315	0.319
P2	1.90	2.00	2.10	0.075	0.079	0.083
A0	6.85	6.90	7.00	0.270	0.271	0.276
B0	10.45	10.50	10.60	0.411	0.413	0.417
K0	2.68	2.78	2.88	0.105	0.109	0.113
T	0.24		0.27	0.009		0.011
t1	0.10			0.004		
10P0	39.80	40.00	40.20	1.567	1.575	1.583