

ESD7V0D9

Description

ESD7V0D9 is designed to protect voltage sensitive components from ESD and transient voltage events. Excellent clamping capability, low leakage, and fast response time, make these parts ideal for ESD protection on designs where board space is at a premium.

Features

- 60 Watts Peak Pulse Power per Line ($t_p=8/20\mu s$)
- Operating voltage: 7V
- Low leakage current
- Package: SOD-923
- Low clamping voltage
- Complies with following standards:
 - IEC 61000-4-2 (ESD) immunity test
 - Air discharge: $\pm 15kV$
 - Contact discharge: $\pm 8kV$



Functional Diagram

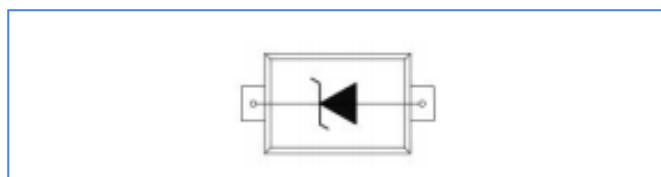

Applications

- Cellular Phones
- Portable Devices
- Digital Cameras
- Power Supplies

Absolute Maximum Ratings ($T_{amb}=25\text{ }^{\circ}C$ unless otherwise specified)

Parameter	Symbol	Value	Unit
Peak Pulse Power (8/20 μs)	P_{PP}	60	Watts
ESD per IEC 61000-4-2 (Air)	V_{ESD}	± 15	KV
ESD per IEC 61000-4-2 (Contact)		± 8	KV
Lead Soldering Temperature	T_L	260 (10 sec)	$^{\circ}C$
Operating Temperature Range	T_J	-55 to +125	$^{\circ}C$
Storage Temperature Range	T_{STJ}	-55 to +150	$^{\circ}C$

Electrical Characteristics (TA = 25 °C unless otherwise noted)

Parameter	Symbol	Conditions	Min.	Typ.	Max.	Units
Reverse Stand-off Voltage	VRWM				7	V
Reverse Breakdown Voltage	VBR	It = 1mA	8			V
Reverse Leakage Current	IR	VR = VRWM			1	μA
Clamping Voltage	VC	I _{PP} =1A, t _P = 8/20μs			10	V
Clamping Voltage	VC	I _{PP} =5A, t _P = 8/20μs			18	V
Junction Capacitance	CJ	VR=0V, f = 1MHz		25	30	pF

Characteristics Curves

Figure 1- Power Derating Curve

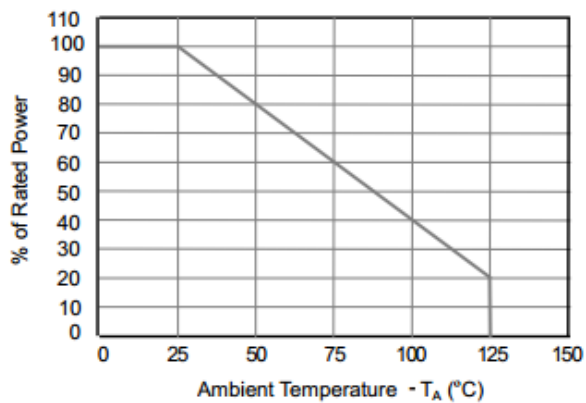
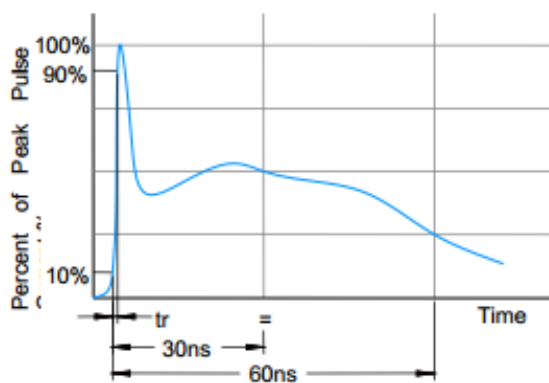
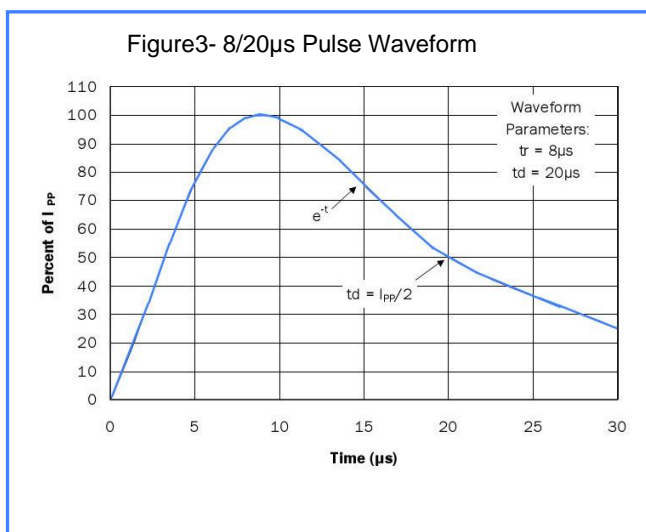
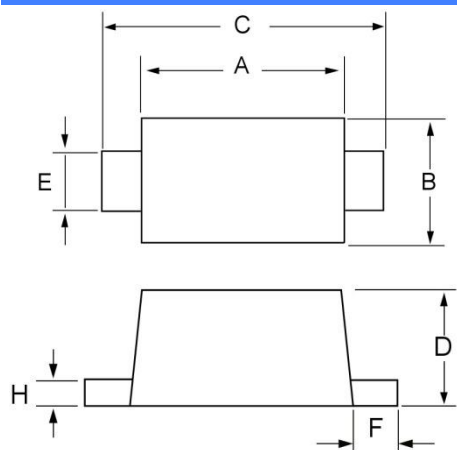

Figure 2- ESD Pulse Waveform (according to IEC 61000-4-2)





PACKAGE OUTLINE DIMENSIONS in millimeters (inches) :



Dim	Inches		Millimeters	
	MIN	MAX	MIN	MAX
A	0.030	0.033	0.75	0.85
B	0.022	0.026	0.55	0.65
C	0.037	0.041	0.95	1.05
D	0.014	0.017	0.36	0.43
E	0.006	0.010	0.15	0.25
F	0.002	0.006	0.05	0.15
H	0.003	0.007	0.07	0.17

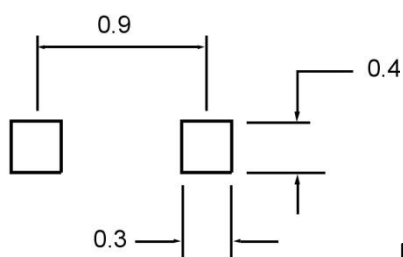

Mounting Pad Layout(mm)

Disclaimer

Specifications are subject to change without notice.
 The device characteristics and parameters in this data sheet can and do vary in different applications and actual device performance may vary over time.
 Users should verify actual device performance in their specific applications.