

Current Mode PWM Power Switch ME8110

General Description

ME8110 integrates a PWM controller and high voltage power MOSFET of 650V. ME8110 has the features of very low startup current and current mode PWM control with green-mode function at light load. The integrated functions of ME8110 also include the leading-edge blanking of the current sensing, internal slope compensation, cycle-by-cycle peak current limiting and soft start. OCP, OVP and OLP provide protection performance for fault conditions. These functions enable the power supply to easily meet even the strictest power requirements.

ME8110 improves the performance and reduces the cost of power supplies.

Features

- Current Mode PWM
- Very low startup current
- Under-Voltage Lockout (UVLO)
- Non-Audible-Noise Green-Mode control
- Fixed 65KHz Switching Frequency
- Cycle-by-Cycle peak current limiting
- Internal leading-edge blanking
- Internal slope compensation
- Less than 0.1W of power saving
- Over-voltage protection (OVP) on VCC pin
- Over-load protection (OLP)
- Available in DIP8 package

Selection Guide

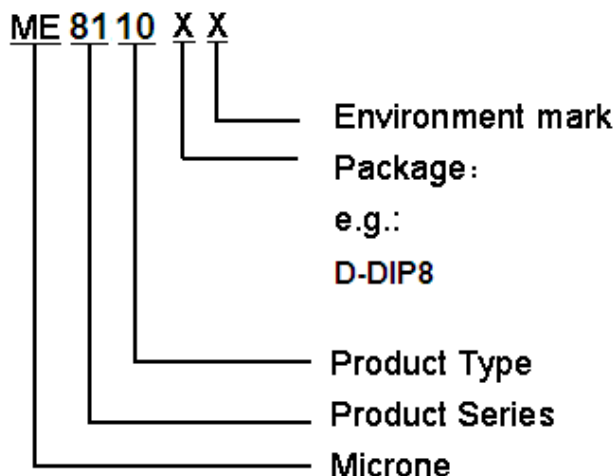

Typical Application

- Switching AC/DC Power battery charge
- Digital cameras
- PDA power supply
- Open-frame SMPS

Pin Configuration

The ME110 is offered in DIP8 packages shown as below.

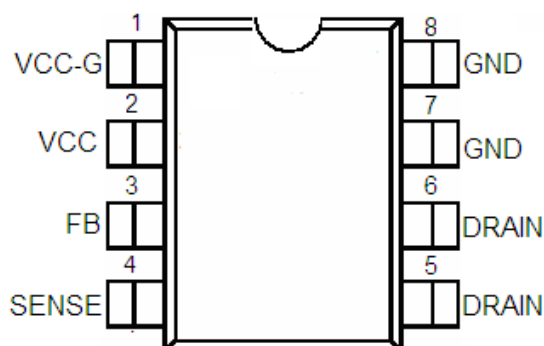

PIN Assignments

Pin Num.	Symbol	Description
1	VCC-G	Power supply input for internal gate driver
2	VCC	Chip DC power supply pin
3	FB	Voltage feedback pin, by connecting a photo-coupler to control the duty cycle
4	SENSE	Current sense input pin. Connected to MOSFET current sensing resistor node.
5、6	DRAIN	Drain of internal HV MOS
7、8	GND	Ground

Absolute Maximum Ratings

Parameter	Range	Unit
VCC DC Supply Voltage	30	V
VCC-G	30	V
Drain Voltage	-0.3~650	V
V_{FB}, V_{SENSE} (Voltage at FB,SENSE to GND)	-0.3 to 7	V
Max Operating Junction Temperature T_J	150	°C
Min/Max Operating Ambient Temperature	-20 to 85	°C
Min/Max Storage Temperature T_{stg}	-65 to 150	°C
Lead Temperature(All Pb free packages, soldering, 10sec)	260	°C
ESD Voltage protection, Human body mode	2000	V
ESD Voltage protection, Machine mode	200	V

Caution: The absolute maximum ratings are rated values exceeding which the product could suffer physical damage.

These values must therefore not be exceeded under any conditions.

Recommended Operating Condition

Parameter	Range	Unit
VCC Supply Voltage	11 to 25	V
VCC-G pin series resistor	51 to 510	Ω
VCC pin series resistor	10 to 75	Ω
FB pin capacitor	1 to 100	nF

Note:

1. FB pin parallel one 6.5V Zener diode for safety regulation on abnormal test.
2. Sense pin resistor recommended to use SMD type for avoiding stray inductor interference issue.

Block Diagram

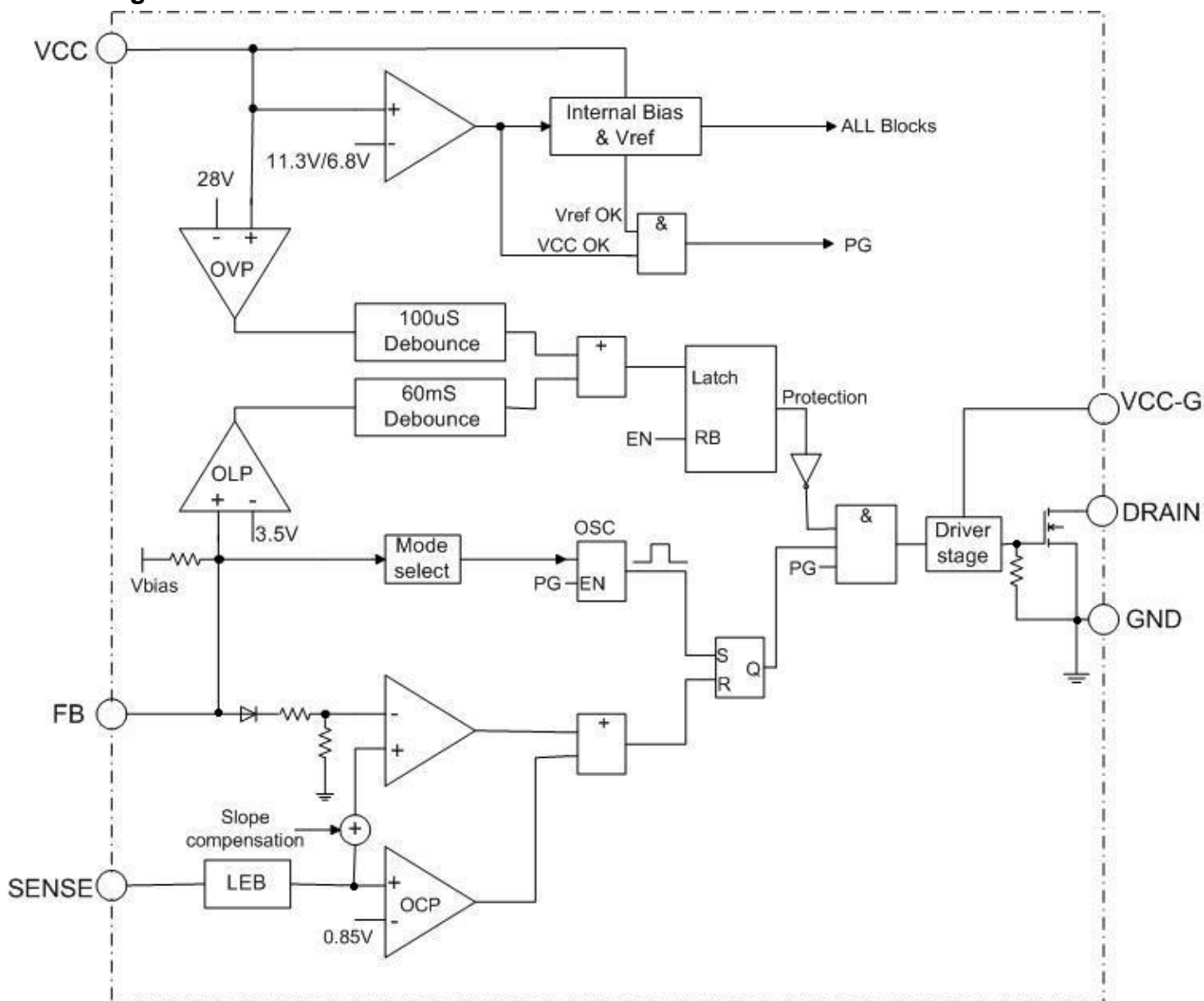

Electrical Characteristics (T_A = 25°C, VCC=15V, if not otherwise noted)

Symbol	Parameter	Test Conditions	Min	Typ.	Max	Unit
Supply Voltage (VCC)						
I _{Startup}	VCC Start up Current	VCC=10.8V, Measure leakage current into VCC	-	5	20	μA
I _{Operation}	Operation Current , with 1nF load on DRAIN pin	V _{FB} =0V, Measure current into VCC pin	400	800	1500	μA
I _{VCC_Operation}	Operation Current	V _{FB} =2.5V, Measure current into VCC pin	-	1.8	-	mA
UVLO _{OFF}	VCC Under Voltage Lockout Enter	VCC Falling	6.3	6.8	7.3	V
UVLO _{ON}	VCC Under Voltage Lockout Exit (Recovery)	VCC Rising	10.8	11.3	11.8	V
OVP _{ON}	VCC Over voltage protection enter		27	28	29	V
Feedback Input Section(FB Pin)						
V _{FB_Open}	V _{FB} Open Loop Voltage	FB pin open	-	5.7	-	V
I _{FB_Short}	FB pin short circuit current	V _{FB} =0V, Short FB pin to GND, measure current	-	0.3	-	mA
Current Sense Input(Sense Pin)						
V _{SENSE_MAX}	Maximum input voltage		0.8	0.85	0.9	V
T _{blanking}	Leading edge blanking time		-	350	-	nS
Z _{SENSE_IN}	Input Impedance		1	-	-	MΩ
T _{D_OC}	Delay to output		-	100	-	nS
Oscillator						
F _{OSC}	Normal Oscillation Frequency		60	65	70	KHz
Δf _{OSC}	Frequency jittering		-	±6	-	%
Δf _{Temp}	Frequency Temperature Stability	-40°C to 110 °C	-	5	-	%
Δf _{VCC}	Frequency Voltage Stability	VCC=11V to 25V	-	3	-	%
F _{Green}	Green Mode Frequency		-	22	-	KHz
MOSFET SECTION						
BV _{DSS}	Drain-Source Voltage	V _{GS} =0	600	-	670	V
R _{on}	Static Drain-Source On-Resistance	I _D =1.0A	-	3.6	4.4	Ω
Duty	Maximum duty cycle		70	75	80	%
Over Load Protection (OLP)						
T _{delay}	OLP Delay time		-	60	-	mS
V _{OLP}	OLP Trim level		-	3.45	-	V

Operation Description

Startup Current

The typical start-up current is $8\mu\text{A}$. Very low start-up current allows the PWM controller to increase the value of start-up resistor and then reduce the power dissipation on it.

Under-voltage Lockout (UVLO)

A hysteresis UVLO comparator is implemented in ME8110, then the turn-on and turn-off thresholds level are fixed on 11.3V and 6.8V respectively. This hysteresis shown in the following figure ensures that the start-up capacitor will be adequate to supply the chip during start-up.

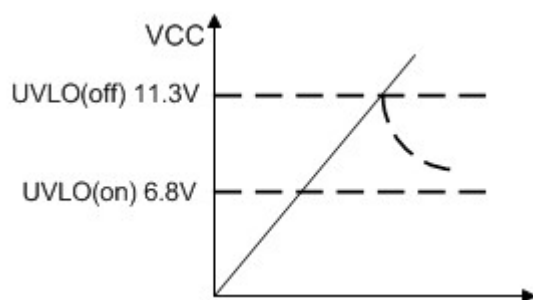

Soft Start

During initial power on, ME8110 provides soft start function. It effectively suppresses the start up peak current to reduce the power MOSFET drain voltage especially at high line.

Oscillator

The frequency of the oscillator is fixed internally at about 65KHz. The maximum duty-cycle of internal oscillator is limited about 75% to avoid the transformer saturation.

Green Mode Operation

When the load decreases to an extent, the frequency of the controller will decrease so as to

reduce the system power consumption. The minimum frequency is about 22KHz, which is outside the audio range.

Leading-edge Blanking (LEB)

Each time the power MOSFET is switched on, a turn-on spike will inevitably occur at the sense resistor. To avoid fault trigger, a 350ns leading-edge blanking time is built in. Conventional RC filtering can therefore be omitted. During this blanking period, the current-limit comparator is disabled and cannot switch off the gate driver.

Over-load Protection (OLP)

The controller has over load protection function. An internal circuit detects the load level, when the load is larger than a threshold and the condition lasts more than 60ms, the gate output will keep low level. Then VCC decreases below UVLO off level, the controller resets again.

Over-voltage Protection (OVP) on VCC

To prevent power MOSFET from being damaged, ME8110 is implemented an OVP function on VCC. When the VCC voltage is higher than the OVP threshold voltage, the output gate driver circuit will be shut down immediately to stop the switching of internal HV power MOSFET. The VCC OVP function is an Auto-recovery type protection. If OVP happens, the pulses will be stopped and recover at the next UVLO on. ME8110 is working in a hiccup mode. Gate Driver Driving capability can be adjusted by a resistor between VCC and VCC-G for EMI improvement. The resistor can decrease rising time of internal gate driver. But be attention that too large resistance could decrease system efficiency (especially at CCM condition).

Typical Application

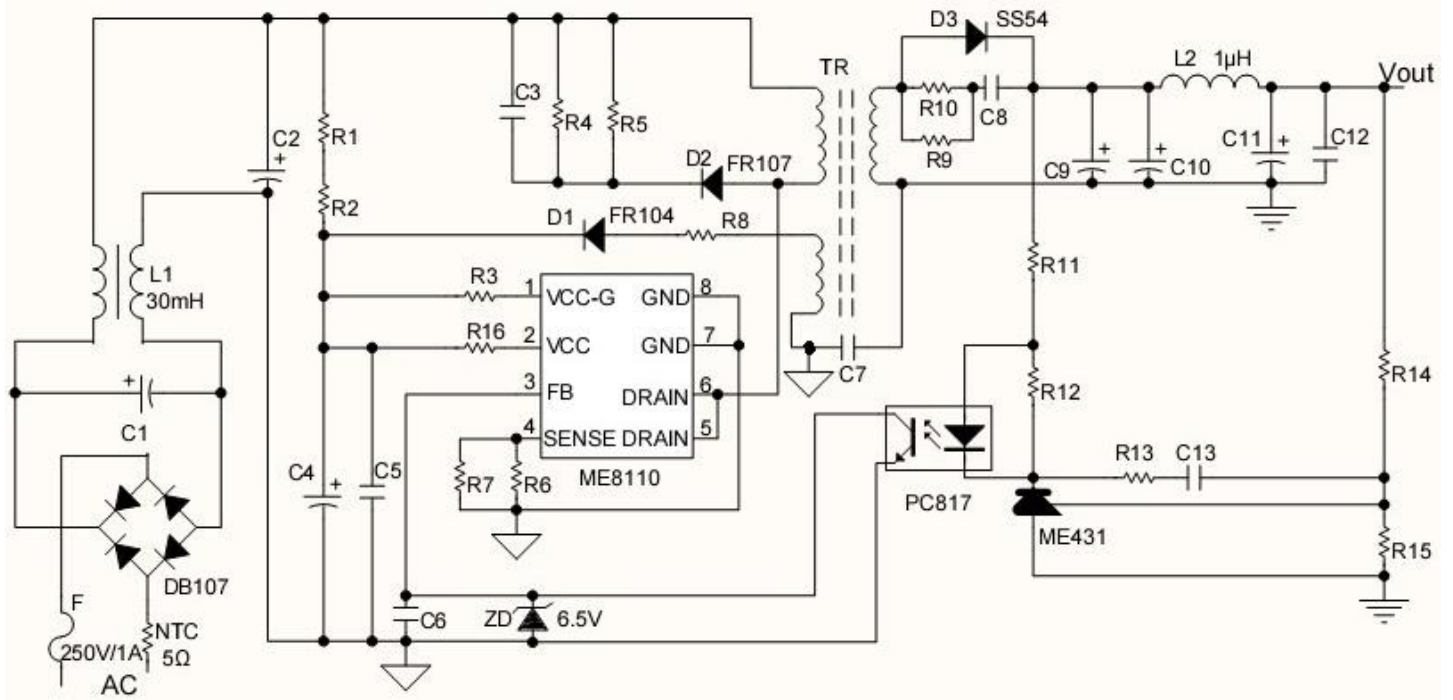

Packaging Information

Package type:DIP8 Unit:mm(inch)

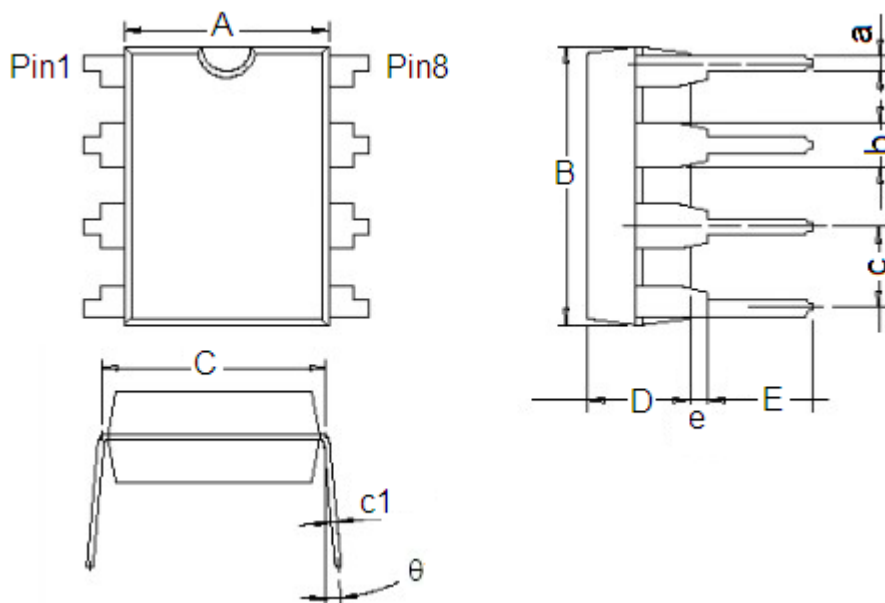

Character	Dimension (mm)		Dimension (Inches)	
	Min	Max	Min	Max
A	6.200	6.600	0.244	0.260
B	9.000	9.400	0.354	0.370
C	7.620(Typ.)		0.300(Typ.)	
D	3.200	3.600	0.126	0.142
E	3.000	3.600	0.118	0.142
a	0.360	0.560	0.014	0.022
b	1.524(Typ.)		0.060(Typ.)	
c	2.54(Typ.)		0.100(Typ.)	
c1	0.204	0.360	0.008	0.014
e	0.510(Min)		0.020(Min)	
theta	0°	15°	0°	15°

- The information described herein is subject to change without notice.
- Nanjing Micro One Electronics Inc is not responsible for any problems caused by circuits or diagrams described herein whose related industrial properties, patents, or other rights belong to third parties. The application circuit examples explain typical applications of the products, and do not guarantee the success of any specific mass-production design.
- Use of the information described herein for other purposes and/or reproduction or copying without the express permission of Nanjing Micro One Electronics Inc is strictly prohibited.
- The products described herein cannot be used as part of any device or equipment affecting the human body, such as exercise equipment, medical equipment, security systems, gas equipment, or any apparatus installed in airplanes and other vehicles, without prior written permission of Nanjing Micro One Electronics Inc.
- Although Nanjing Micro One Electronics Inc exerts the greatest possible effort to ensure high quality and reliability, the failure or malfunction of semiconductor products may occur. The user of these products should therefore give thorough consideration to safety design, including redundancy, fire-prevention measures, and malfunction prevention, to prevent any accidents, fires, or community damage that may ensue.