



ULTRA-SMALL PACKAGE PWM/PFM SWITCHING CONTROL

STEP-UP SWITCHING REGULATOR

General Description

The ME2109 series is a CMOS step-up switching regulator which mainly consists of a reference voltage source, an oscillation circuit, an error amplifier, a phase compensation circuit, a PWM/PFM switching control circuit. With an external low-ON-resistance Nch Power MOS, this product is applicable to applications requiring high efficiency and high output current. The ME2109 series switches its operation to the PFM control circuit whose duty ratio is 15 % with to the PWM/PFM switching control circuit under a light load and to prevent decline in the efficiency by IC operation current.

Features

- Low voltage operation: Start-up is guaranteed from 0.9V(IOUT =1 mA)
- Duty ratio: Built-in PWM/PFM switching control circuit 15 to 78 % .
- oscillator frequency: 300KHz
- External parts: coil, diode, capacitor, and transistor
- Output voltage range: 1.5V ~20 V
- Output voltage accuracy: $\pm 2\%$
- Soft start function: 2 ms.

Applications

- Mobile phones (PDC, GSM, CDMA, IMT200 etc.)
- Bluetooth equipment
- PDA
- Portable communication modem
- Portable games
- Cameras
- Digital cameras
- Cordless phones
- Notebook computers

Package

- 5-pin SOT23-5

Typical Application Circuit

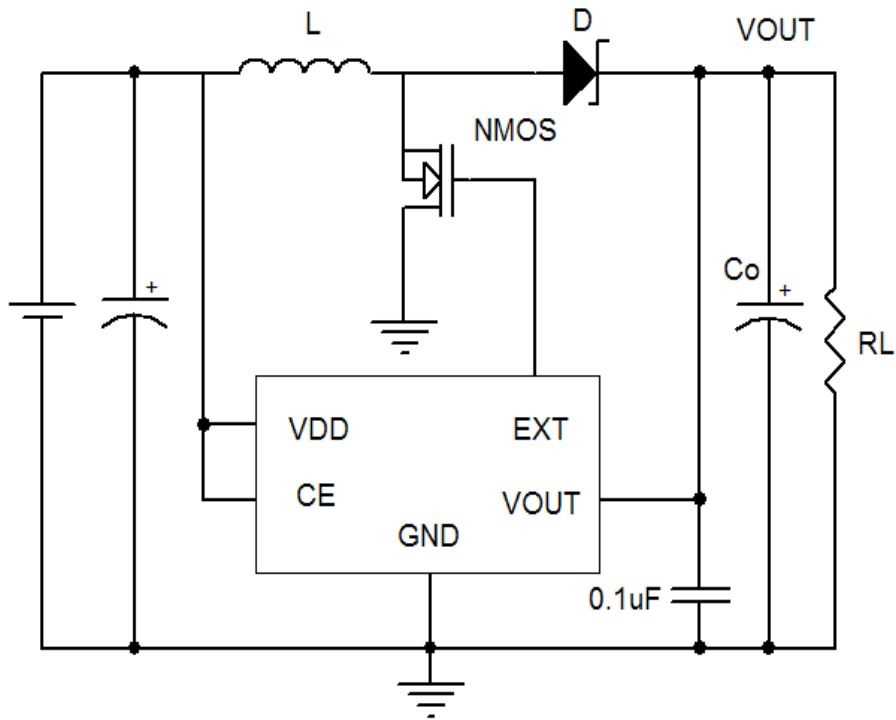

Fig.1 For use external transistor

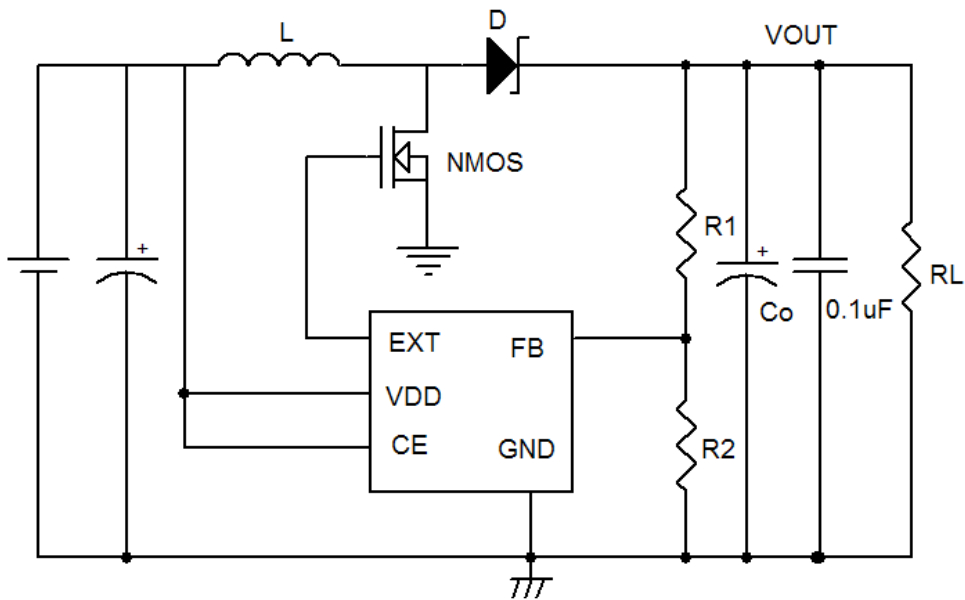
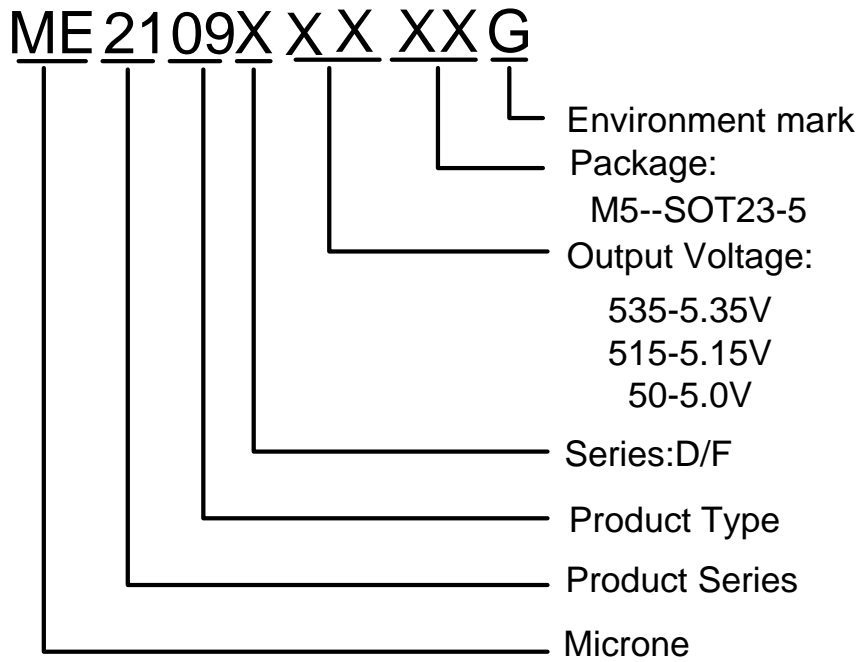

Fig.2 For Feedback and external transistor

Selection Guide



product series	switching transistor	CE function	VDD function	FB function	features
ME2109D535M5G	External Transistor	Yes	Yes	No	Ext + Enable
ME2109D515M5G					
ME2109D50M5G					
ME2109FM5G	External Transistor	Yes	Yes	Yes	Ext +Feedback

Pin Configuration

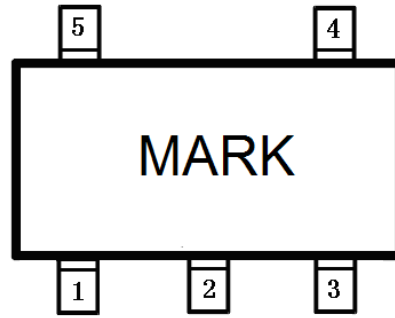

SOT-23-5

Pin Assignment

ME2109DxxM5G

Pin Number	Pin Name	Function
SOT-23-5		
1	VOUT	Output voltage pin
2	VDD	IC power supply pin
3	CE	Shutdown pin
4	GND	GND pin
5	EXT	External transistor connection pin

ME2109FM5G

Pin Number	Pin Name	Function
SOT-23-5		
1	FB	Feed Back voltage pin
2	VDD	IC power supply pin
3	CE	Shutdown pin
4	GND	GND pin
5	EXT	External transistor connection pin

Block Diagram

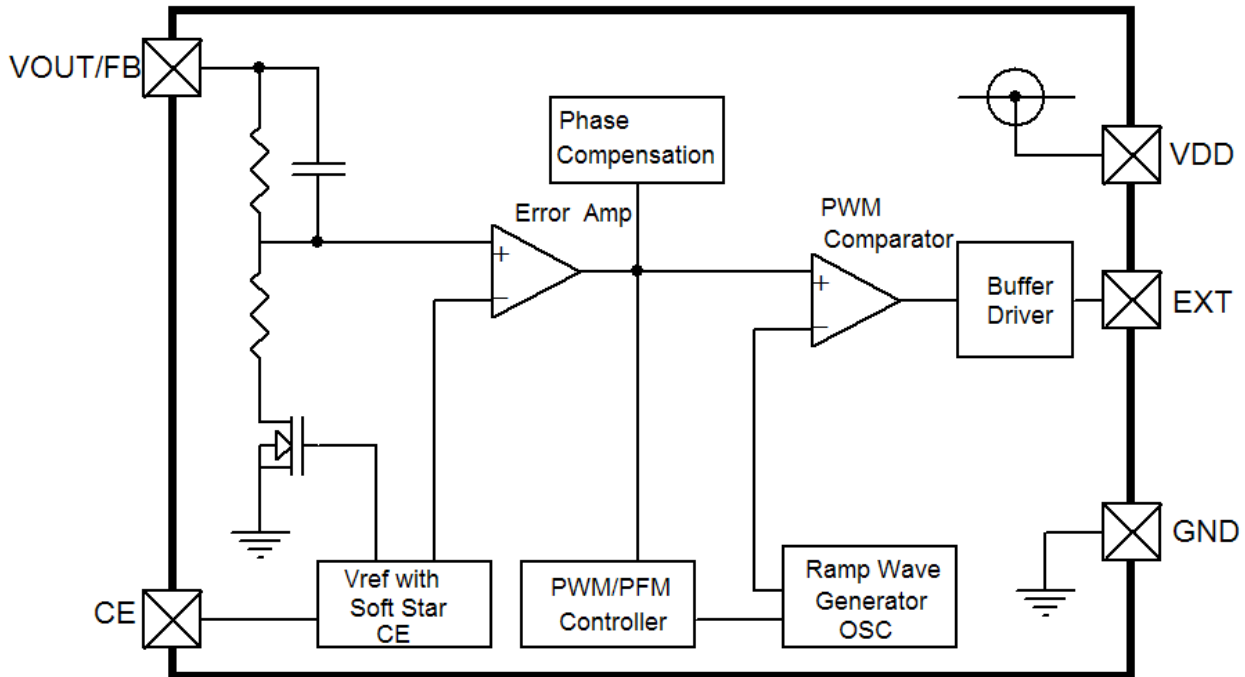

Absolute Maximum Rangs

PARAMETER	SYMBOL	RATINGS	UNITS
VDD Pin Voltage	VDD	-0.3~6.5	V
EXT Pin Voltage	EXT	-0.3~VDD+0.3	V
VOUT Pin Voltage	VOUT	-0.3~6.5	V
CE Pin Voltage	VCE	-0.3~Vin+0.3	V
EXT Pin Voltage	IEXT	±1000	mA
Power Dissipation (SOT23-5)	Pd	300	mW
OperatingTemperature Range	T _{Opr}	-25~+85	°C
StorageTemperature Range	T _{stg}	-40~+125	°C

Electrical Characteristics

ME2109DxxG

Measuring conditions: $V_{IN}=V_{OUT(S)}\times 0.6, I_{OUT}=100\text{mA}, V_{CE}=V_{DD}, T_{opt}=25^{\circ}\text{C}$. Unless otherwise specified.

Parameter	Symbol	Condition	Min	Typ.	Max	Unit	Circuit	
Output voltage	VOUT	-	$V_{OUT(S)}\times 0.98$	VOUT(S)	$V_{OUT(S)}\times 1.02$	V	2	
Input voltage	VDD	-	-	-	6	V	2	
Operation start voltage	VST	$I_{OUT}=1\text{mA}$	-	-	0.9	V	2	
Operation holding voltage	VHLD	$I_{OUT}=1\text{mA}$, Measured by decreasing V_{IN} voltage gradually	0.7	-	-	V	2	
Current consumption 1	ISS1	$V_{OUT}=V_{OUT(S)}\times 0.95$	-	200	-	μA	1	
Current consumption 2	ISS2	$V_{OUT}=V_{OUT(S)}+0.5\text{V}$	-	20	-	μA	1	
Current consumption during shutdown	ISSS	$V_{CE}=0\text{V}$	-	0.1	0.5	μA	1	
EXT pin output current	IEXTH	$V_{EXT}=V_{OUT}-0.4\text{V}$	-	-35	-	mA	1	
	IEXTL	$V_{EXT}=0.4\text{V}$	-	55	-	mA	1	
Line regulation	ΔV_{OUT1}	$V_{DD}=V_{OUT(S)}\times 0.4\sim\times 0.6$	-	30	-	mV	2	
Load regulation	ΔV_{OUT2}	$I_{OUT}=10\mu\text{A}\sim V_{OUT}/50\times 1.25$	-	35	-	mV	2	
Output voltage temperature coefficient		$T_a=-25\sim 85^{\circ}\text{C}$	-	± 50	-	ppm/ $^{\circ}\text{C}$	2	
Oscillation frequency	fosc	$V_{OUT}=V_{OUT(S)}\times 0.95$	255	300	345	kHz	1	
Max. duty ratio	MAXDUTY	$V_{OUT}=V_{OUT(S)}\times 0.95$	-	78	-	%	1	
PWM/PFM switching duty ratio	PFMDUTY	$V_{DD}=V_{OUT(S)}-0.1\text{V}$, no load	-	15	-	%	1	
Shutdown pin input voltage	VSH	Measured the oscillation at EXT pin	0.75	-	-	V	1	
	VSL1	Judged the stop of oscillation at EXT pin	$V_{OUT}\geq 1.5\text{V}$	-	-	0.3	V	1
	VSL2		$V_{OUT}< 1.5\text{V}$	-	-	0.2	V	1
Shutdown pin input voltage	ISH	$V_{CE} = V_{OUT(S)} \times 0.95$	-0.1	-	0.1	μA	1	
	ISL	$V_{CE}=0\text{V}$	-0.1	-	0.1	μA	1	
Soft start time	tss	-		2		mS	2	
Efficiency	EFFI	-		85		%	2	

ME2109FxxG

Measuring conditions: VDD=VCE=3.3V, T_{opt}=25°C。 Unless otherwise specified.

Parameter	Symbol	Condition	Min	Typ.	Max	Unit	Circuit	
Feed back voltage	VOUT	-	1.225	1.25	1.275	V	4	
Input voltage	VIN	-		-	6	V	4	
Operation start voltage	VST	I _{OUT} =1mA	-	-	0.9	V	4	
Operation holding voltage	VHLD	I _{OUT} =1mA, Measured by decreasing VIN voltage gradually	0.7	-	-	V	4	
Current consumption 1	ISS1	VFB=VFB(S)× 0.95	-	100	-	uA	3	
Current consumption 2	ISS2	VFB=1.5V	-	15	-	uA	3	
Current consumption during shutdown	ISSS	VCE=0V	-	0.01	0.5	uA	3	
EXT pin output current	IEXTH	VEXT=VOUT-0.4V	-	-25	-	mA	3	
	IEXTL	VEXT=0.4V	-	40	-	mA	3	
Feed back voltage temperature coefficient		T _a =-25—85°C	-	±50	-	ppm/°C	4	
Oscillation frequency	fosc	-	255	300	345	kHz	3	
Max. duty ratio	MAXDUTY	VFB=VFB(S)× 0.95	-	78	-	%	3	
PWM/PFM switching duty ratio	PFMDUTY	VFB=VFB(S)× 1.5, no load	-	15	-	%	3	
Shutdown pin input voltage	VSH	Measured the oscillation at EXT pin	0.75	-	-	V	3	
	VSL1	Judged the stop of oscillation at EXT pin	VOUT≥1.5V	-	-	0.3	V	3
	VSL2		VOUT<1.5V	-	-	0.2	V	3
Shutdown pin input voltage	ISH	VCE=VFB(S)×0.95	-0.1	-	0.1	uA	3	
	ISL	VCE=0V	-0.1	-	0.1	uA	3	
Soft start time	tss	-	-	2	-	mS	4	
Efficiency	EFFI	-	-	85	-	%	4	

1. VOUT(S) is the set output voltage value, and VOUT is the typical value of the output voltage.
2. VOUT(S) can be set by using the rate of VFB and output voltage setting resistors (R1, R2).
3. VFB(S) is the set output voltage value.
4. This product from the start when the VDD=0.9V booster work, but in order to stabilize the output voltage and oscillation frequency, to control the VDD, $1.8V \leq VDD < 6V$.

Test Circuit:

1.

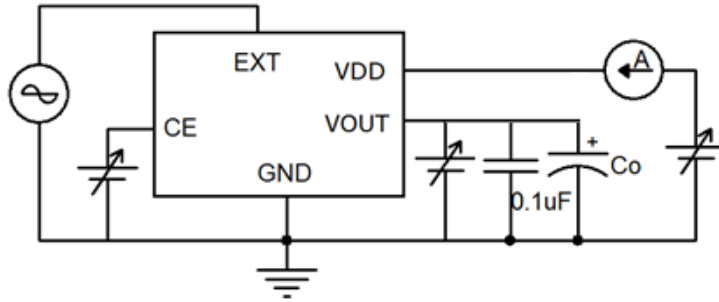

2.

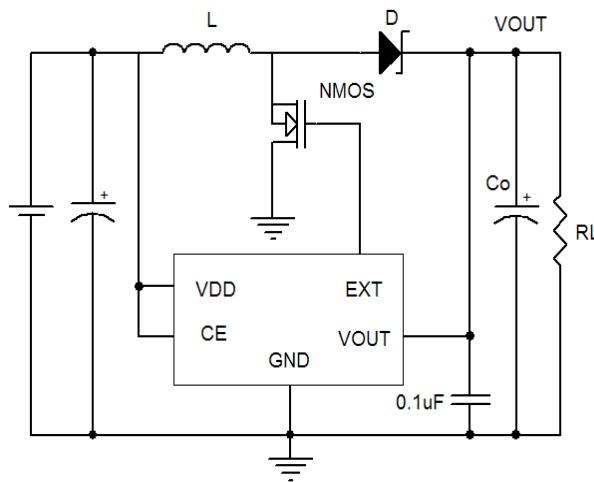

3.

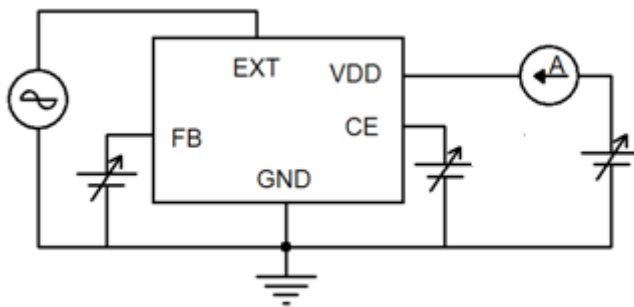

4.

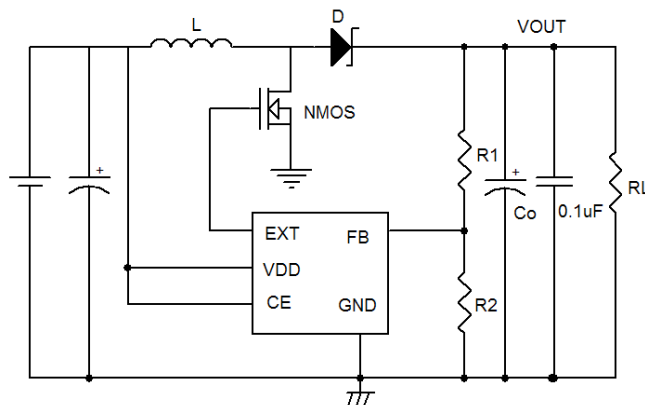

External parts (suggest)

- 1、Diode use Schottky diode such as IN5817 or IN5819 (forward voltage drop:0.2V)
- 2、NMOS: MEM8205 or MEM2310
- 3、Inductor: 22 μ H ($r < 0.5\Omega$)
- 4、Capacitor: Tantalum type 47uF
- 5、Feed back resistors: $R1+R2 < 50K$

External parts selection for DC/DC converter

The relationship between major characteristics of the step-up circuit and characteristics parameters of the external parts are shown in Figure 1.

<u>For larger output current?</u>	<u>For high efficiency?</u>		<u>For smaller ripple voltage?</u>
	Operation efficiency	Stand-by efficiency	
Smaller inductance	Larger inductance		
Smaller DC resistance of inductor			
Large output capacitance			Large output capacitance
With MOSFET, smaller ON resistance		With MOSFET, smaller input capacitance	
With bipolar transistor, smaller external resistance R_b		With bipolar transistor, larger external resistance R_b	

Figure 1 Relationship between major characteristics of the step-up circuit and external parts

1. Inductor

An inductance has strong influence on maximum output current I_{OUT} and efficiency η .

Figure 2 shows the relation between I_{OUT} , and η characteristics to L of ME2109.

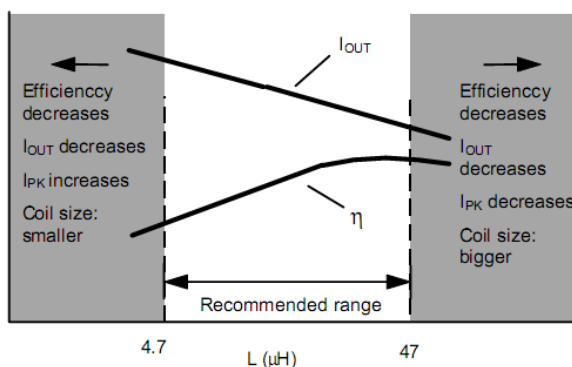

Figure 2 L— I_{OUT} and η characteristics

The peak current (IPK) increases by decreasing L and the stability of a circuit improves and IOUOUT increases. If L is furthermore made small, efficiency falls and in running short, IOUOUT decreases. (Based on the current drive capability of external switching transistor.)

The loss of IPK by the switching transistor decreases by increasing L and the efficiency becomes maximum at a certain L value. Further increasing L decreases efficiency due to the loss of DC resistance of the coil. Also, IOUOUT decreases, too.

Oscillation frequency is higher, smaller one can be choosed and also makes coil smaller. The recommended inductances are 22 to 100 μ H inductor for ME2109.

Choose a value for L by referring to the reference data because the maximum output current is due to the input voltage in an actual case. Choose an inductor so that IPK does not exceed the allowable current. Exceeding the allowable current of the inductor causes magnetic saturation, remarkable low efficiency and destruction of the IC chip due to a large current.

IPK in uncontinuous mode is calculated from the following equatuon

$$I_{PK} = \sqrt{\frac{2I_{OUT}(V_{OUT} + V_D - V_{IN})}{f_{OSC} \cdot L}} (A)$$

fosc = oscillation frequency, $V_D \cong 0.4$ V.

2. Diode

Use an external diode that meets the following requirements:

- Low forward voltage: ($V_F < 0.3$ V)
- High switching speed: (50 ns max.)
- Reverse voltage: $V_{OUT} + V_F$ or more
- Rated current: I_{PK} or more

3. Capacitor (CIN, Co)

A capacitor at the input side (CIN) improves the efficiency by reducing the power impedance and stabilizing the input current. Select a CIN value according to the impedance of the power supply used.

A capacitor at the output side (Co) is used for smoothing the output voltage. For step-up types, the output voltage flows intermittently to the load current so that step-up types need a larger capacitance than step-down types. Therefore, select an appropriate capacitor depending on the ripple voltage that increases in case of a higher output voltage or a higher load current. The capacitor value should be 10 μ F minimum.

Select an appropriate capacitor with an ESR (Equivalent Series Resistance) for stable output voltage. A stable range of the volatge at this IC depends on the ESR. Although the inductance (L) is also a factor, an ESR of 30 m Ω to 500 m Ω draws out the characteristics. However, the best ESR may depend on L, capacitance, wiring and applications (output load). Therefore, fully evaluate ESRs under an actual condition to determine the best value.

4. Enhancement MOS FET type

Depending on the MOS FET you use in your device, there is a chance of a current overrun at power ON. Thoroughly test all settings with your device before deciding on which one to use. Also, try to use a MOS FET with the input capacitance of 700 pF or less.

Since the ON resistor of the MOS FET might depend on the difference between the output voltage V_{OUT} and the threshold voltage of MOS FET, and affect the output current as well as the efficiency, the threshold voltage should be low. When the output voltage is low, the circuit operates only when the MOS FET has the threshold voltage lower than the output voltage.

5. Precautions

- Mount external capacitors, a diode, and a coil as close as possible to the IC.
- Unique ripple voltage and spike noise occur in switching regulators. Because they largely depend on the coil and the capacitor used, check them using an actually mounted model.
- Make sure dissipation of the switching transistor (especially at a high temperature) does not exceed the allowable power dissipation of the package.
- The performance of this IC varies depending on the design of the PCB patterns, peripheral circuits and external parts. Thoroughly test all settings with your device. Also, try to use recommended external parts.

Typical Performance Characteristics

1. Output Waveforms

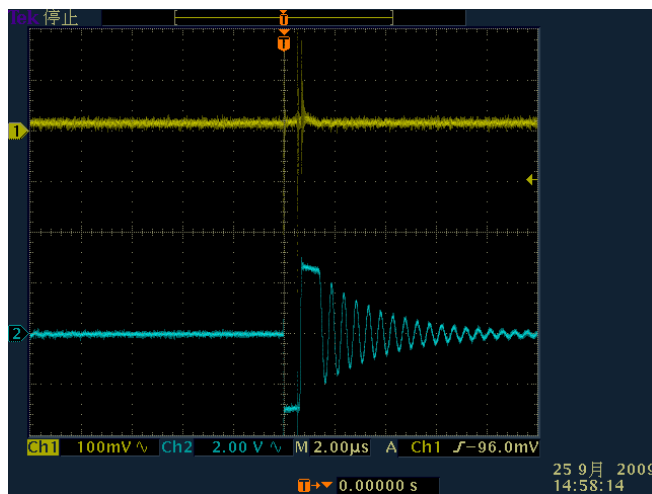

Iout=1mA

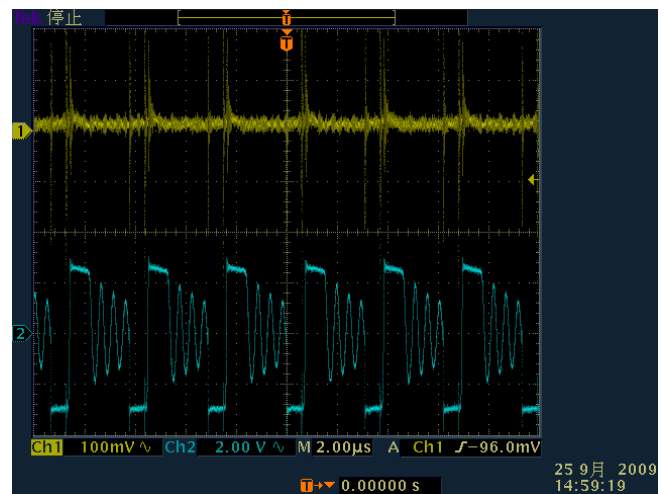

Iout=10mA

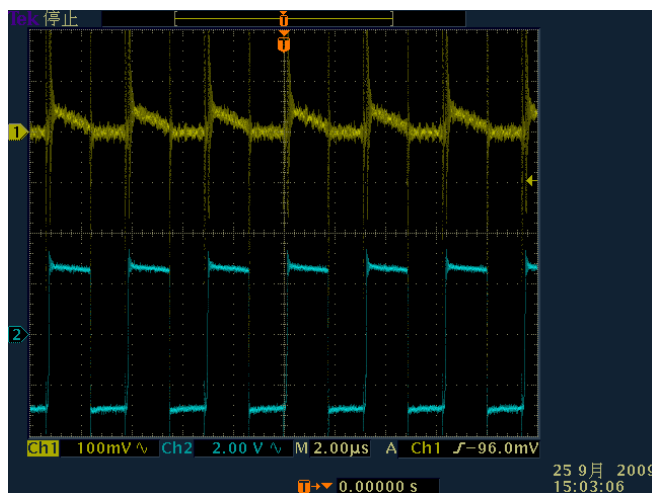

Iout=100mA

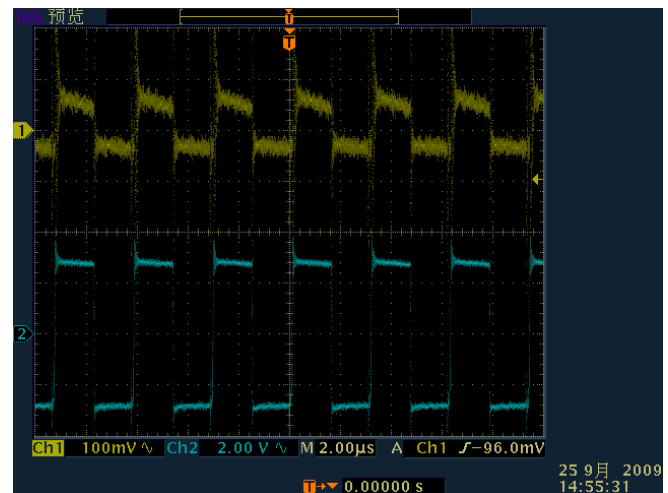

Iout=200mA

2. Transient Response characteristics

(1) Powering ON (V_{in} : 0→2V)

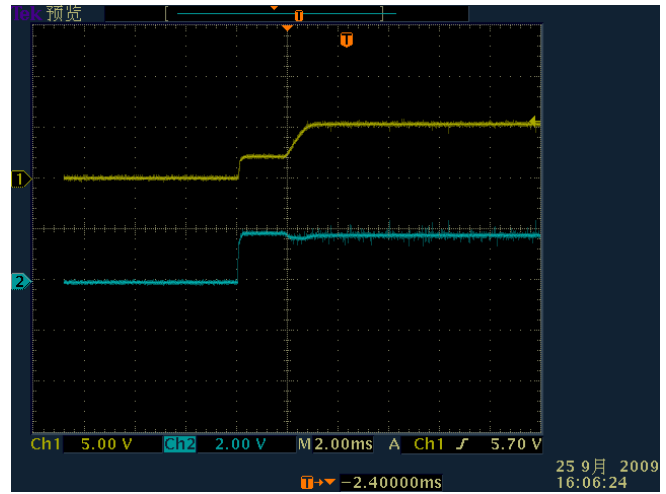
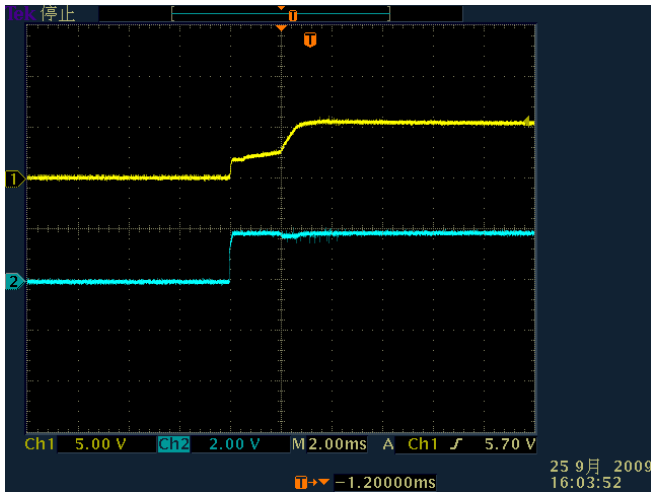

(2) Responses of CE pin (CE : 0→2V)

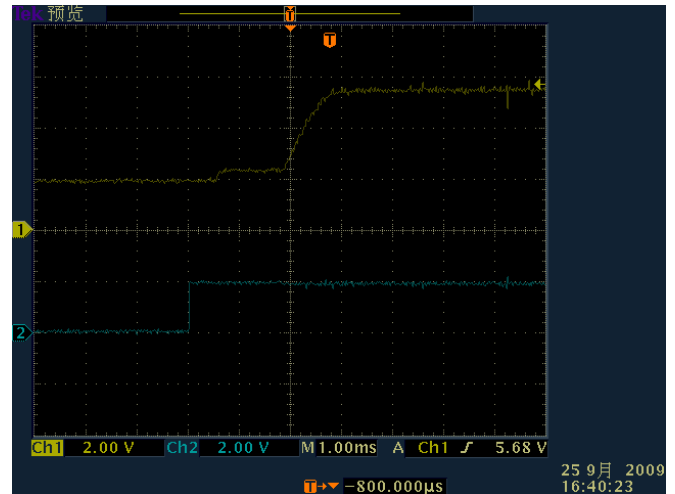
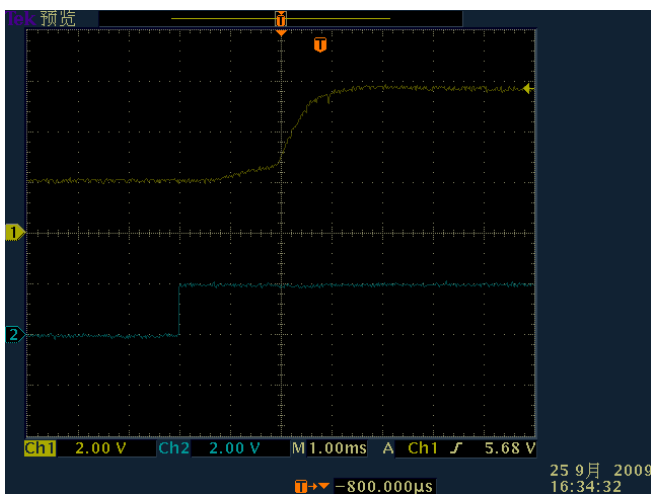

3. Output Current vs. Output Voltage

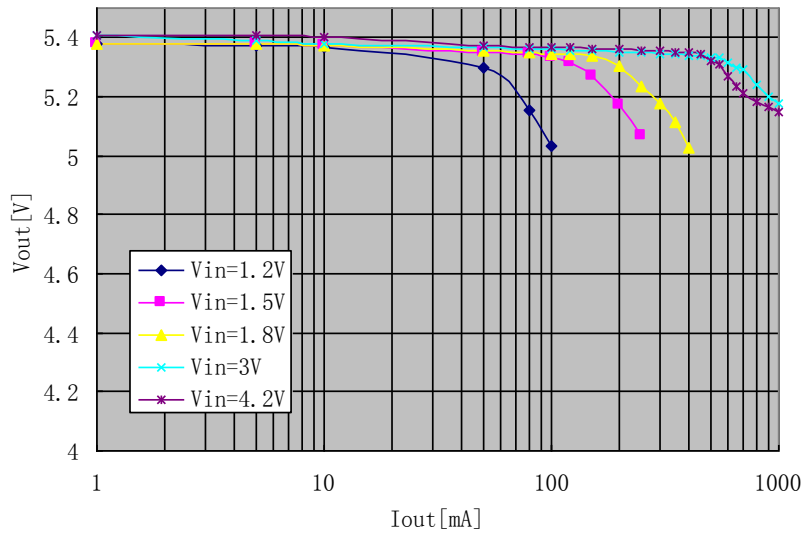

4. Output Current vs. Efficiency

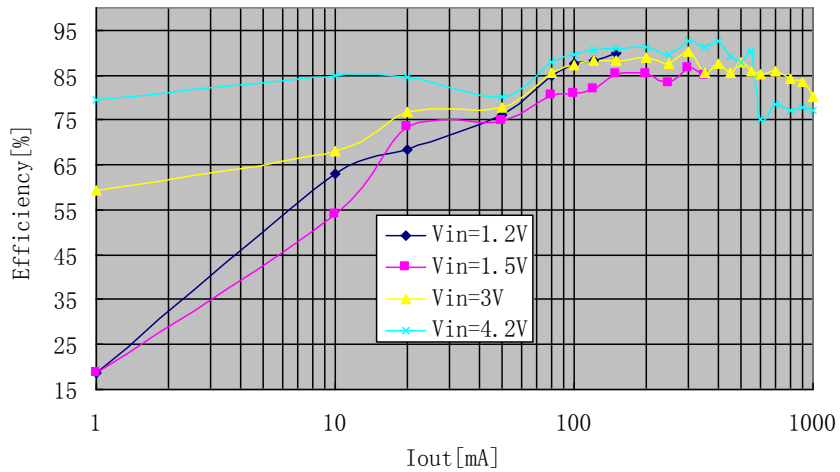

Packaging Information

● SOT23-5

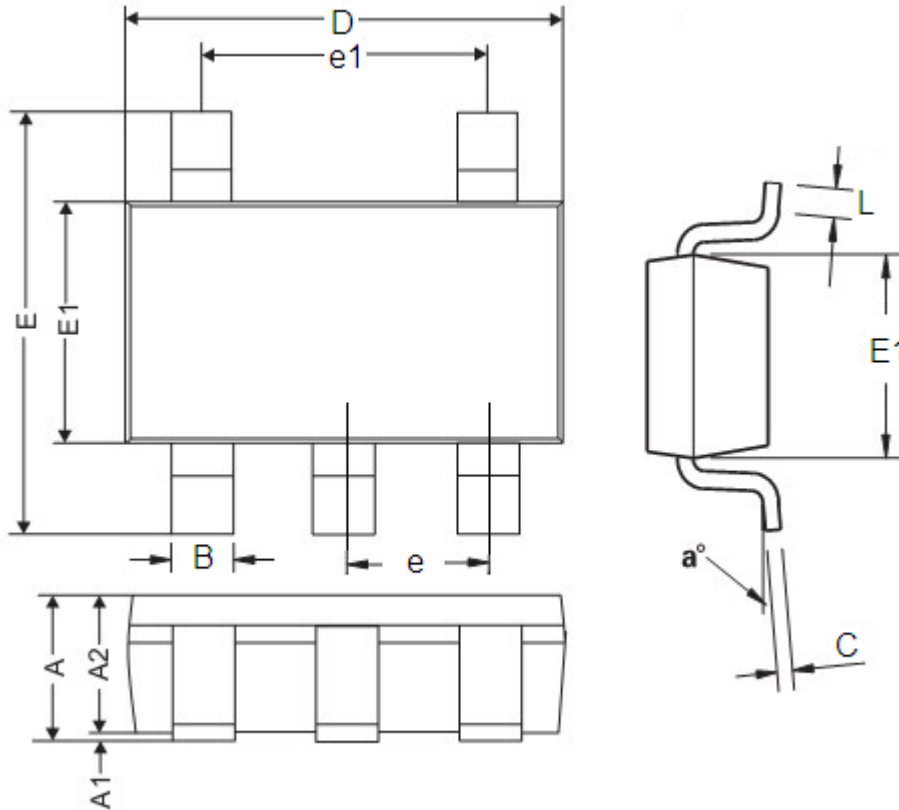

DIM	Millimeters		Inches	
	Min	Max	Min	Max
A	0.9	1.45	0.0354	0.0570
A1	0	0.15	0	0.0059
A2	0.9	1.3	0.0354	0.0511
B	0.2	0.5	0.0078	0.0196
C	0.09	0.26	0.0035	0.0102
D	2.7	3.10	0.1062	0.1220
E	2.2	3.2	0.0866	0.1181
E1	1.30	1.80	0.0511	0.0708
e	0.95REF		0.0374REF	
e1	1.90REF		0.0748REF	
L	0.10	0.60	0.0039	0.0236
a°	0°	30°	0°	30°

- The information described herein is subject to change without notice.
- Nanjing Micro One Electronics Inc is not responsible for any problems caused by circuits or diagrams described herein whose related industrial properties, patents, or other rights belong to third parties. The application circuit examples explain typical applications of the products, and do not guarantee the success of any specific mass-production design.
- Use of the information described herein for other purposes and/or reproduction or copying without the express permission of Nanjing Micro One Electronics Inc is strictly prohibited.
- The products described herein cannot be used as part of any device or equipment affecting the human body, such as exercise equipment, medical equipment, security systems, gas equipment, or any apparatus installed in airplanes and other vehicles, without prior written permission of Nanjing Micro One Electronics Inc.
- Although Nanjing Micro One Electronics Inc exerts the greatest possible effort to ensure high quality and reliability, the failure or malfunction of semiconductor products may occur. The user of these products should therefore give thorough consideration to safety design, including redundancy, fire-prevention measures, and malfunction prevention, to prevent any accidents, fires, or community damage that may ensue.