

Low power consumption, Low dropout voltage, With CE function ME6213 Series

General Description

ME6213 series are highly precise, low power consumption, high voltage, positive voltage regulators manufactured using CMOS and laser trimming technologies. The series provides large currents with a significantly small dropout voltage. The current limiter's foldback circuit also operates as a short protect for the output current limiter and the output pin. The CE function allows the output of regulator to be turned off, resulting in greatly reduced power consumption.

Features

- Highly Accurate: $\pm 2\%$
- Output voltage range: 1.2V~5.0V
- Low power consumption: 7.5 μ A(TYP.)
- Large output current: 300mA ($V_{IN}=3.8V, V_{OUT}=2.8V$)
- Input voltage: up to 6 V
- Dropout voltage:
0.11V at 100mA and 0.23V at 200mA
- CE Pin Function : Active High
- Short-circuit Current: 45mA(TYP.)
- Excellent Input Stability
- Be available to regulator and reference voltage
- Packages:SOT23-5

Selection Guide

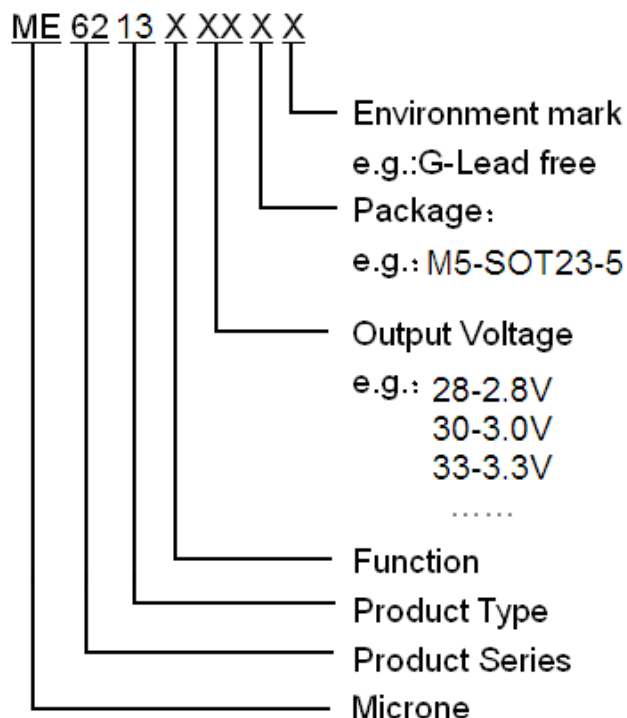

Typical Application

- Battery powered equipment
- Communication tools
- Mobile phones
- Portable games
- Portable AV systems
- Cameras, Video systems
- Reference voltage sources

Typical Application Circuit

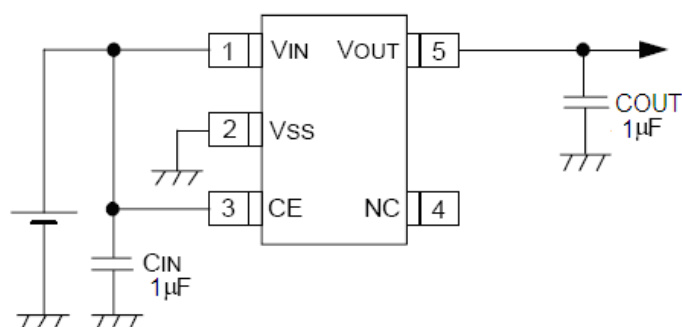

Pin Configuration

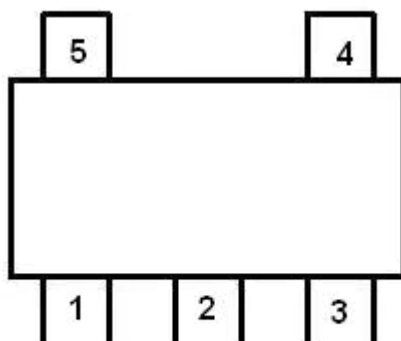

SOT23-5

Pin Assignment

ME6213CXX

Pin Number	Pin Name	Functions
SOT23-5		
1	V_{IN}	Power Input
2	V_{SS}	Ground
3	CE	ON / OFF Control
4	NC	No Connect
5	V_{OUT}	Output

Absolute Maximum Ratings

Parameter	Symbol	Ratings	Units
Input Voltage	V_{IN}	6.5	V
Output Current	I_{OUT}	420	mA
Output Voltage	V_{OUT}	$V_{SS}-0.3 \sim V_{IN} + 0.3$	V
CE Pin Voltage	V_{CE}	$V_{SS}-0.3 \sim V_{IN} + 0.3$	V
Power Dissipation	SOT23-5 P_D	250	mW
Operating Temperature Range	T_{OPR}	$-40 \sim +125$	$^{\circ}C$
Storage Temperature Range	T_{STG}	$-40 \sim +150$	$^{\circ}C$
Lead Temperature		$260^{\circ}C, 4sec$	

Block Diagram

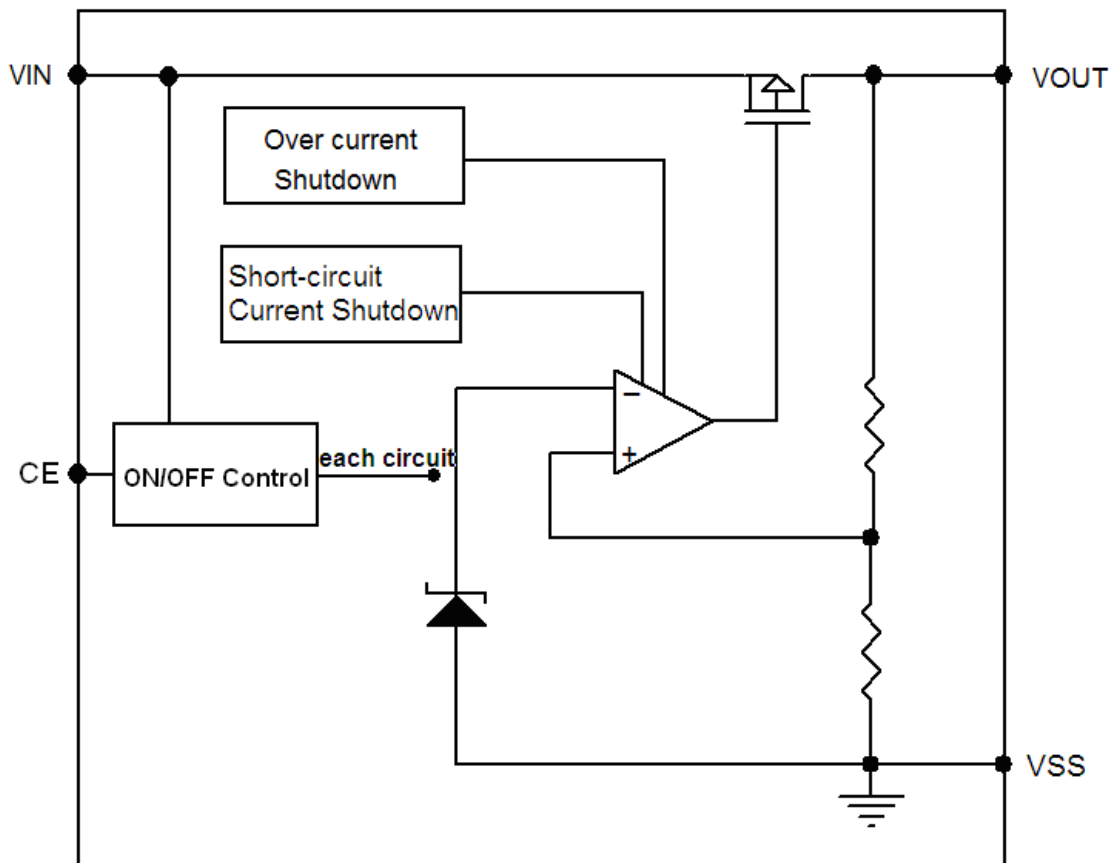

Electrical Characteristics

ME6213C28

($V_{IN} = V_{OUT} + 1V$, $V_{CE} = V_{IN}$, $C_{IN} = C_{OUT} = 1\mu F$, $T_a = 25^\circ C$, unless otherwise noted)

Parameter	Symbol	Conditions	Min.	Typ.	Max.	Units
Output Voltage	$V_{OUT(E)}$ (Note 2)	$I_{OUT} = 30mA$, $V_{IN} = V_{OUT} + 1V$	X 0.98	$V_{OUT(T)}$ (Note 1)	X 1.02	V
Input Voltage	V_{IN}		2.8		6	V
Maximum Output Current	I_{OUTMAX}	$V_{IN} = V_{OUT} + 1V$		300		mA
Load Regulation	ΔV_{OUT}	$V_{IN} = V_{OUT} + 1V$, $1mA \leq I_{OUT} \leq 100mA$		4		mV
Dropout Voltage (Note 1)	V_{DIF1}	$I_{OUT} = 100mA$		110		mV
	V_{DIF2}	$I_{OUT} = 200mA$		230		mV
Supply Current	I_{SS}	$V_{IN} = V_{OUT} + 1V$		7.5		μA
Stand-by Current	I_{CEL}	$V_{CE} = 0V$		0.02		μA
Line Regulation	ΔV_{OUT}	$I_{OUT} = 30mA$ $V_{OUT} + 1V \leq V_{IN} \leq 6V$		5		mV
CE "High" Voltage	VCEH	Start up	1.0			V
CE "Low" Voltage	VCEL	Shut down			0.5	V
Short-circuit Current	I_{SHORT}	$V_{IN} = V_{OUT} + 1V$, $V_{CE} = V_{IN}$, $V_{OUT} = 0V$		45		mA
Over Current Protection	I_{limit}	$V_{IN} = 3.8V$		430		mA

Note :

- $V_{OUT(T)}$: Specified Output Voltage
- $V_{OUT(E)}$: Effective Output Voltage (i.e. The output voltage when " $V_{OUT(T)} + 1.0V$ " is provided at the Vin pin while maintaining a certain Iout value.)
- V_{DIF} : $V_{IN1} - V_{OUT(E)}$
 V_{IN1} : The input voltage when $V_{OUT(E)}$ appears as input voltage is gradually decreased.
 $V_{OUT(E)}$ = A voltage equal to 98% of the output voltage whenever an amply stabilized Iout { $V_{OUT(T)} + 1.0V$ } is input.

Type Characteristics (ME6213C28)

(1) Output Voltage VS. Output Current

($V_{IN}=V_{OUT}+1$, $T_a = 25\text{ }^\circ\text{C}$)

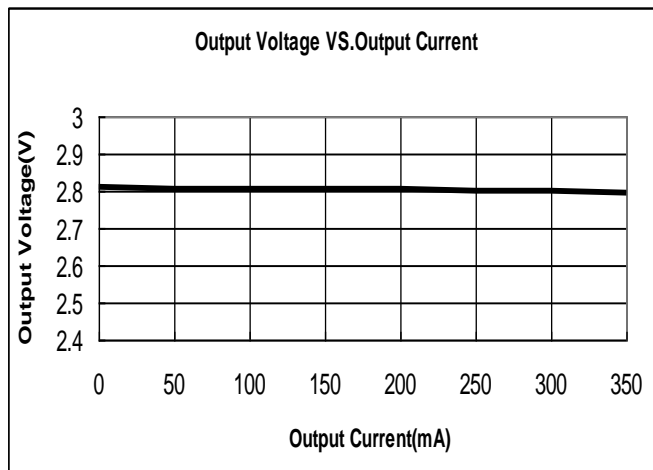

(2) Output Voltage VS. Input Voltage

($T_a = 25\text{ }^\circ\text{C}$)

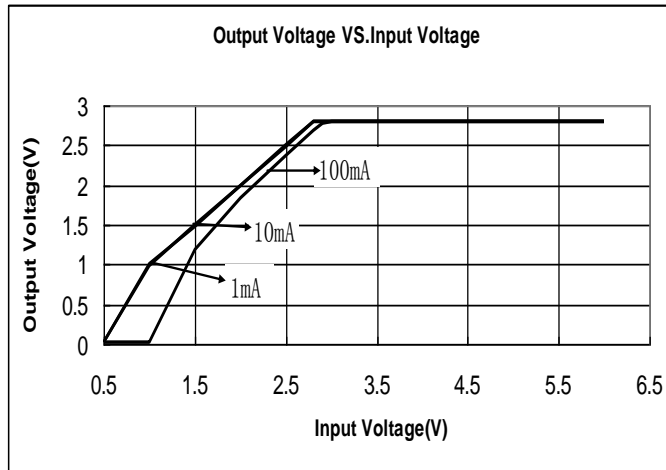

(3) Dropout Voltage VS. Output Current

($V_{IN}=V_{OUT}+1V$, $T_a = 25\text{ }^\circ\text{C}$)

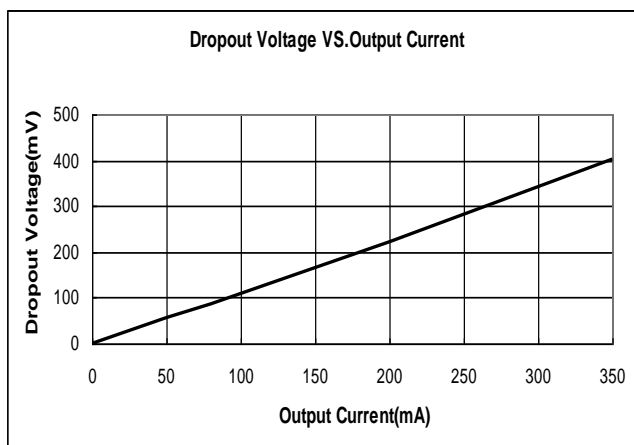

(4) Supply Current VS. Input Voltage

($T_a = 25\text{ }^\circ\text{C}$)

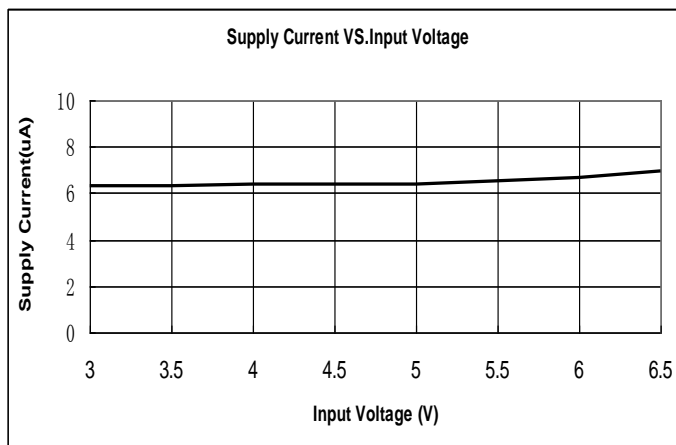

(5) Output Voltage VS. Temperature ($V_{IN}=V_{OUT}+1V$, $I_{OUT} = 10mA$)

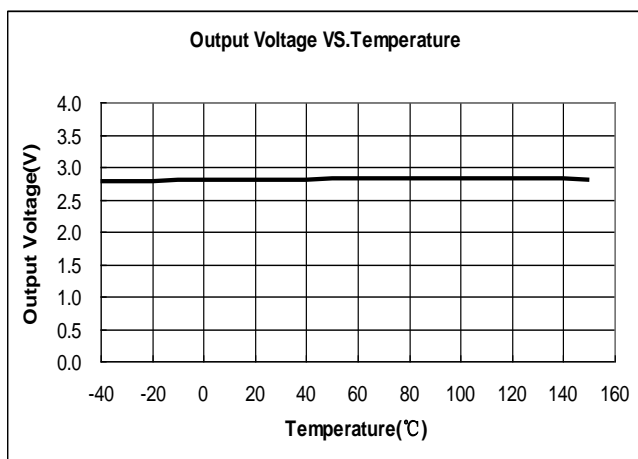

Packaging Information

● SOT23-5

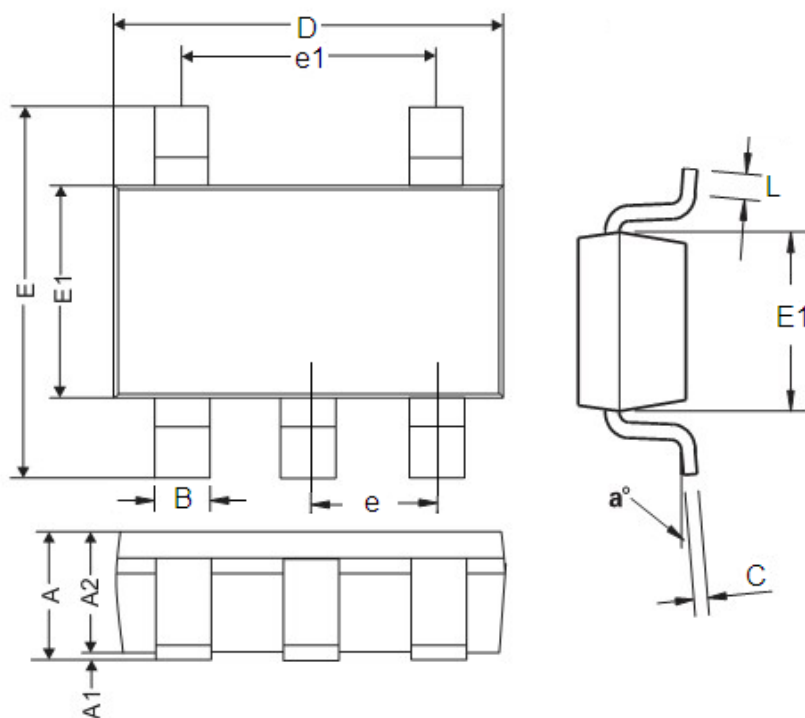

DIM	Millimeters		Inches	
	Min	Max	Min	Max
A	0.9	1.45	0.0354	0.0570
A1	0	0.15	0	0.0059
A2	0.9	1.3	0.0354	0.0511
B	0.2	0.5	0.0078	0.0196
C	0.09	0.26	0.0035	0.0102
D	2.7	3.10	0.1062	0.1220
E	2.2	3.2	0.0866	0.1181
E1	1.30	1.80	0.0511	0.0708
e	0.95REF		0.0374REF	
e1	1.90REF		0.0748REF	
L	0.10	0.60	0.0039	0.0236
a°	0°	30°	0°	30°

- The information described herein is subject to change without notice.
- Nanjing Micro One Electronics Inc is not responsible for any problems caused by circuits or diagrams described herein whose related industrial properties, patents, or other rights belong to third parties. The application circuit examples explain typical applications of the products, and do not guarantee the success of any specific mass-production design.
- Use of the information described herein for other purposes and/or reproduction or copying without the express permission of Nanjing Micro One Electronics Inc is strictly prohibited.
- The products described herein cannot be used as part of any device or equipment affecting the human body, such as exercise equipment, medical equipment, security systems, gas equipment, or any apparatus installed in airplanes and other vehicles, without prior written permission of Nanjing Micro One Electronics Inc.
- Although Nanjing Micro One Electronics Inc exerts the greatest possible effort to ensure high quality and reliability, the failure or malfunction of semiconductor products may occur. The user of these products should therefore give thorough consideration to safety design, including redundancy, fire-prevention measures, and malfunction prevention, to prevent any accidents, fires, or community damage that may ensue.