

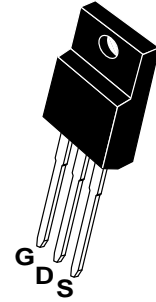

Features:

- Low Intrinsic Capacitances
- Excellent Switching Characteristics
- Extended Safe Operating Area
- Unrivalled Gate Charge :Qg= 22nC (Typ.)
- BVDSS=700V, ID=8A
- R_{DS(on)} : 1.2 Ω (Max) @VG=10V
- 100% Avalanche Tested



Schematic diagram

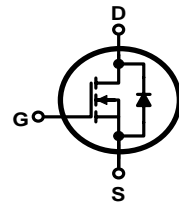

- Y = Year
- A = Assembly Location
- WW = Work Week
- VA = Version & Assembly plant
- FIR8N70F = Specific Device Code

Absolute Maximum Ratings (Ta=25°C unless otherwise noted)

Symbol	Parameter	Value	Unit
V _{DSS}	Drain-Source Voltage	700	V
I _D	Drain Current	T _C =25°C	8
		T _C =100°C	5.2
V _{GS(TH)}	Gate Threshold Voltage	±30	V
E _{AS}	Single Pulse Avalanche Energy (note1)	540	mJ
I _{AR}	Avalanche Current (note2)	8	A
P _D	Power Dissipation (Tc=25°C)	50	W
T _j	Junction Temperature(Max)	150	°C
T _{stg}	Storage Temperature	-55~+150	°C
TL	Maximum lead temperature for soldering purpose, 1/8" from case for 5 seconds	300	°C

Thermal Characteristics

Symbol	Parameter	Typ.	Max.	Unit
R _{θJC}	Thermal Resistance, Junction to Case	-	2.5	°C/W
R _{θJA}	Thermal Resistance, Junction to Ambient	-	120	°C/W

**Electrical Characteristics** Tc=25°C unless other wise noted

Symbol	Parameter	Test Condition	Min.	Typ.	Max	Units
Off Characteristics						
BV _{DSS}	Drain-Source Breakdown Voltage	ID=250 μ A, VGS=0	700	--	--	V
$\frac{\Delta BV_{DSS}}{\Delta T_J}$	Breakdown Voltage Temperature Conficient	ID=250 μ A, Reference to 25°C	--	0.77	--	V/°C
IDSS	Zero Gate Voltage Drain Current	Vds=700V, Vgs=0V	--	--	10	μ A
		Vds=560V, Tc=125°C			100	μ A
IGSSF	Gate-body leakage Current, Forward	Vgs=+30V, Vds=0V	--	--	100	nA
IGSSR	Gate-body leakage Current, Reverse	Vgs=-30V, Vds=0V	--	--	-100	nA
On Characteristics						
V _{GS(th)}	Date Threshold Voltage	Id=250uA, Vds=Vgs	2	--	4	V
R _{DS(on)}	Static Drain-Source On-Resistance	Id=4A, Vgs=10V	--	0.95	1.2	Ω
Dynamic Characteristics						
Ciss	Input Capacitance	VDS=25V, VGS=0, f=1.0MHz	--	1300	--	pF
Coss	Output Capacitance		--	135	--	pF
Crss	Reverse Transfer Capacitance		--	7.5	--	pF
Switching Characteristics						
Td(on)	Turn-On Delay Time	VDD=350V, ID=7.5A RG=25 Ω (Note 3,4)	--	35	--	nS
Tr	Turn-On Rise Time		--	50	--	nS
Td(off)	Turn-Off Delay Time		--	120	--	nS
Tf	Turn-Off Fall Time		--	50	--	nS
Qg	Total Gate Charge	VDS=560, VGS=10V, ID=7.5A (Note 3,4)	--	22	--	nC
Qgs	Gate-Source Charge		--	6.5	--	nC
Qgd	Gate-Drain Charge		--	6.5	--	nC
Drain-Source Diode Characteristics and Maximum Ratings						
I _S	Maximun Continuous Drain-Source Diode Forward Current		--	--	8	A
I _{SM}	Maximun Plused Drain-Source Diode Forwad Current		--	--	30	A
V _{SD}	Drain-Source Diode Forward Voltage	Id=7.5A	--	--	1.5	V
trr	Reverse Recovery Time	I _S =7.5A, V _{GS} =0V	--	370	--	nS
Qrr	Reverse Recovery Charge	di _F /dt=100A/ μ s (Note3)	--	3.3	--	μ C

*Notes 1, L=25.0mH, IAS=7.0A, VDD=50V, RG=25Ω, Starting T_J=25°C

2, Repetitive Rating : Pulse width limited by maximum junction temperature

3, Pulse Test : Pulse Width ≤ 300μs, Duty Cycle ≤ 2%

4, Essentially Independent of Operating Temperature

Typical Characteristics

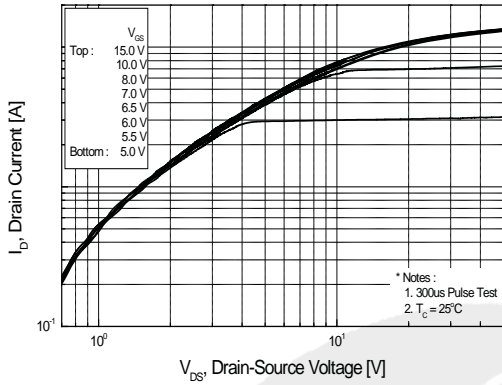

Figure 1. On Region Characteristics

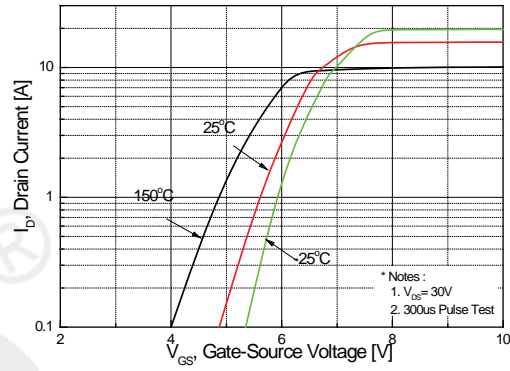

Figure 2. Transfer Characteristics

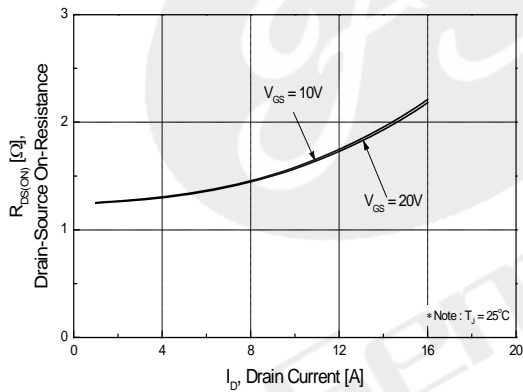

Figure 3. On Resistance Variation vs Drain Current and Gate Voltage

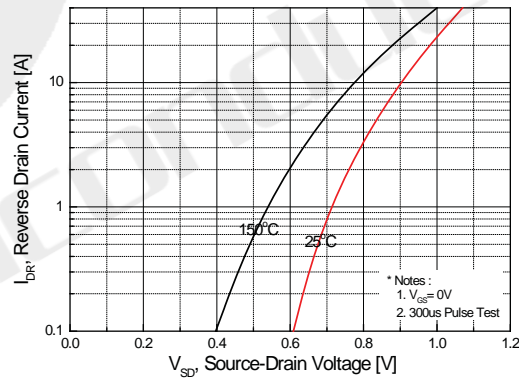

Figure 4. Body Diode Forward Voltage Variation with Source Current and Temperature

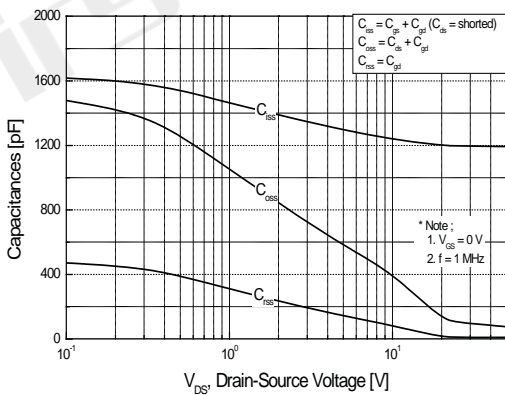

Figure 5. Capacitance Characteristics

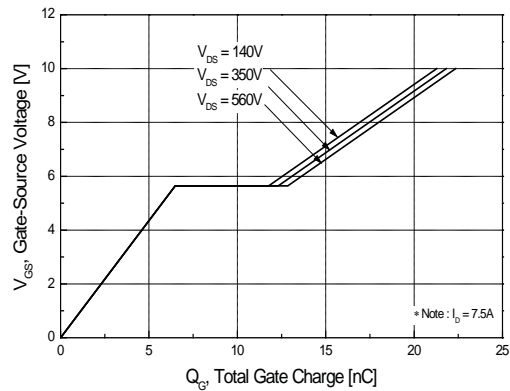

Figure 6. Gate Charge Characteristics

Typical Characteristics (Continued)

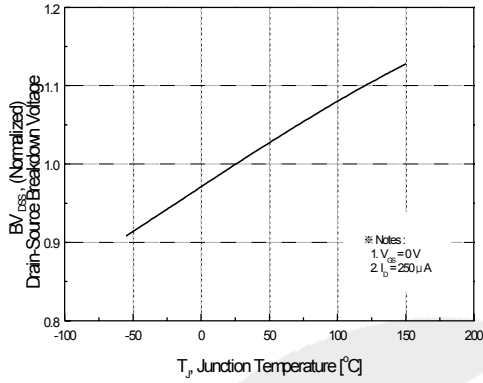

Figure 7. Breakdown Voltage Variation vs Temperature

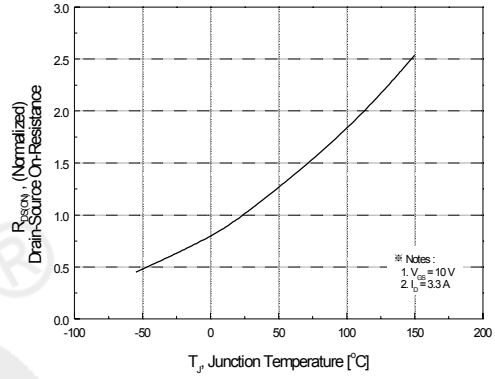

Figure 8. On-Resistance Variation vs Temperature

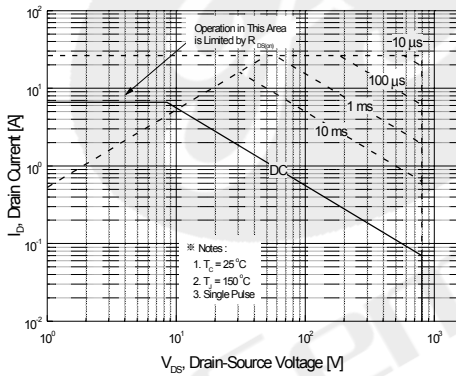

Figure 9-2. Maximum Safe Operating Area

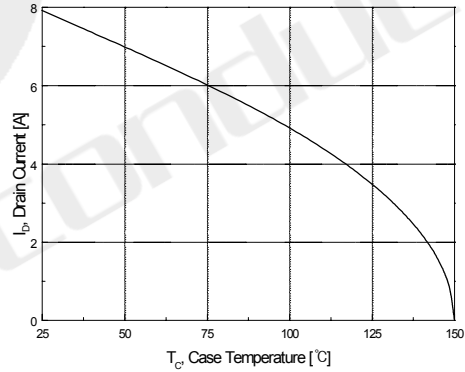

Figure 10. Maximum Drain Current vs Case Temperature

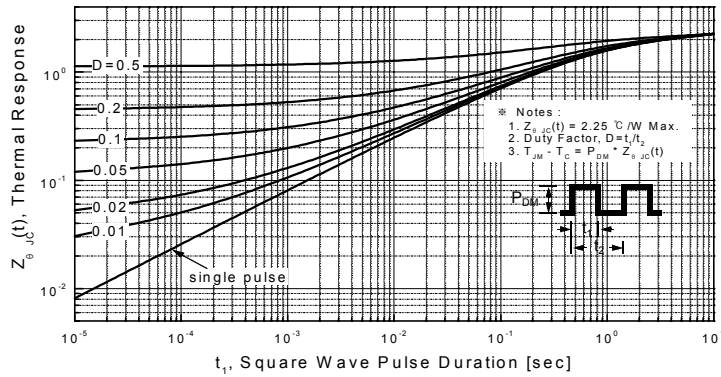
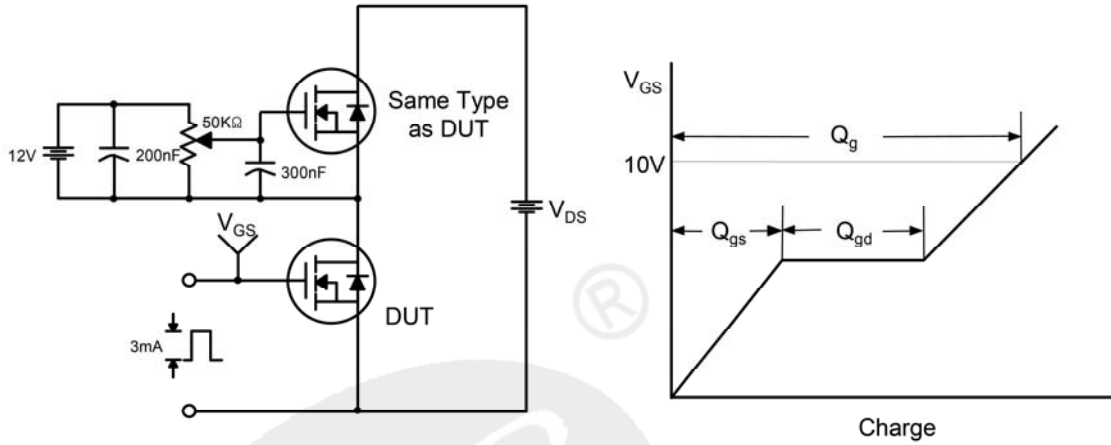
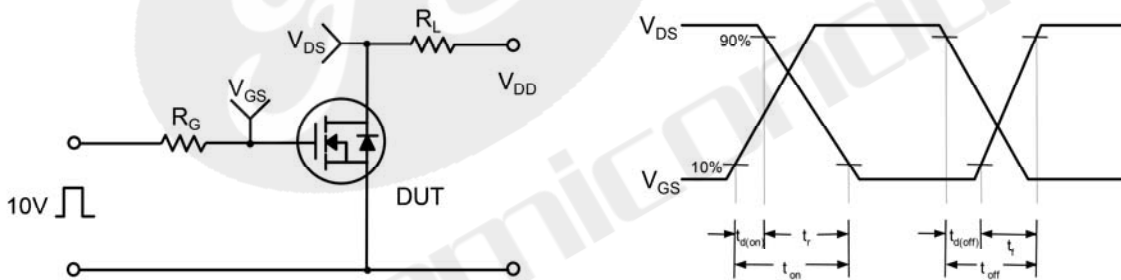

Figure 11-2. Transient Thermal Response Curve

Gate Charge Test Circuit & Waveform



Resistive Switching Test Circuit & Waveforms



Unclamped Inductive Switching Test Circuit & Waveforms

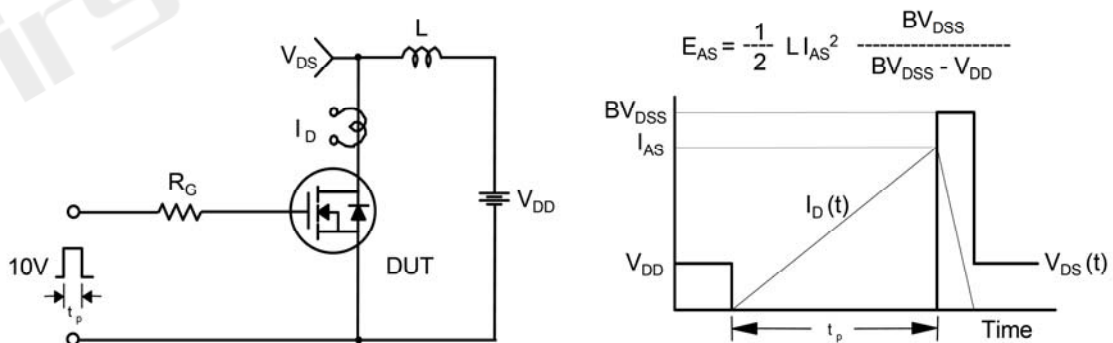

Peak Diode Recovery dv/dt Test Circuit & Waveform

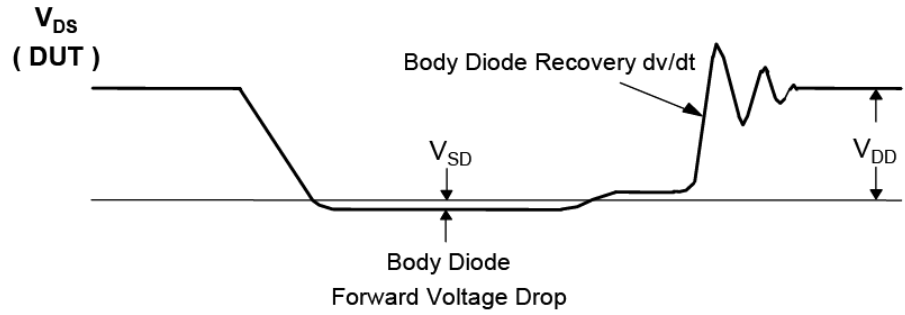
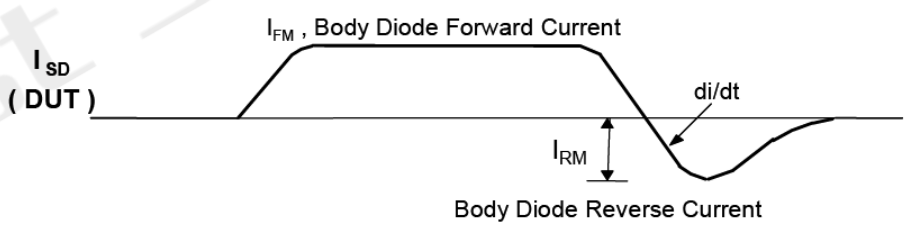
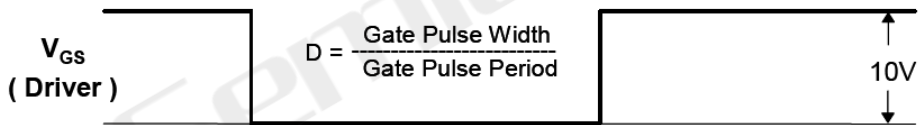
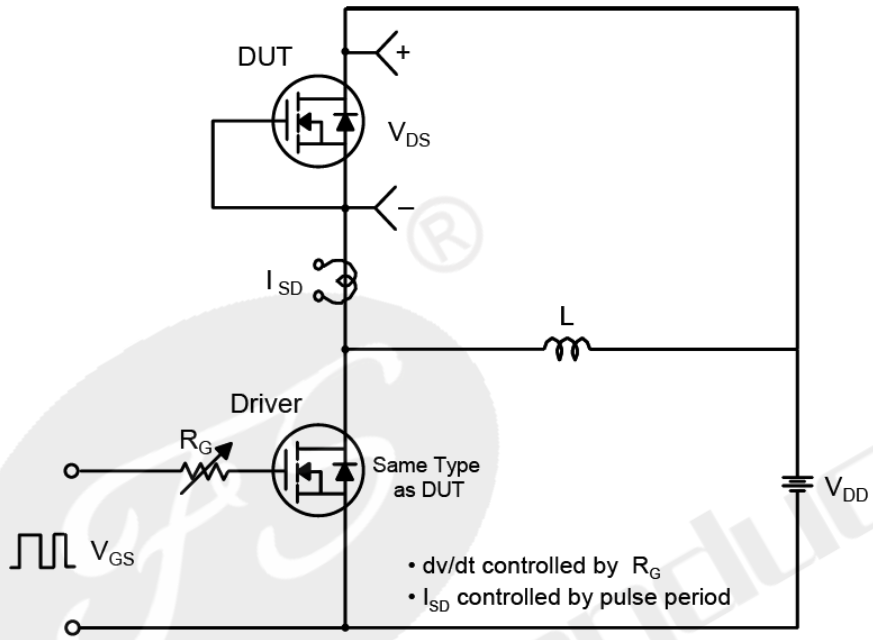



Package Dimension

TO-220F

Unit: mm

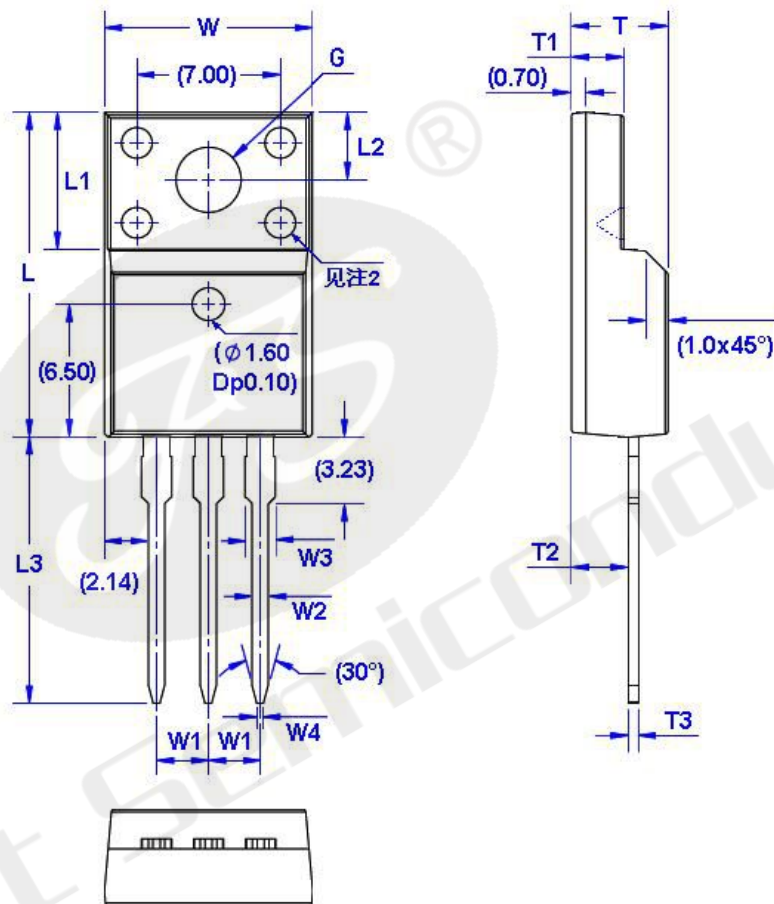

Symbol	Size		Symbol	Size		Symbol	Size		Symbol	Size	
	Min	Max		Min	Max		Min	Max		Min	Max
W	9.96	10.36	W4	0.25	0.45	L3	12.78	13.18	T3	0.45	0.60
W1	2.54	(TYP)	L	15.67	16.07	T	4.50	4.90	G(Φ)	3.08	3.28
W2	0.70	0.90	L1	6.48	6.88	T1	2.34	2.74			
W3	1.24	1.47	L2	3.20	3.40	T2	2.56	2.96			



Declaration

- FIRST reserves the right to change the specifications, the same specifications of products due to different packaging line mold, the size of the appearance will be slightly different, shipped in kind, without notice! Customers should obtain the latest version information before ordering, and verify whether the relevant information is complete and up-to-date.
- Any semiconductor product under certain conditions has the possibility of failure or failure, The buyer has the responsibility to comply with safety standards and take safety measures when using FIRST products for system design and manufacturing, To avoid To avoid potential failure risks, which may cause personal injury or property damage!
- Product promotion endless, our company will wholeheartedly provide customers with better products!

ATTACHMENT

Revision History

Date	REV	Description	Page
2018.01.01	1.0	Initial release	