



PIN Connection TO-251

Description

The FIR12N15BPG uses advanced trench technology and design to provide excellent $R_{DS(ON)}$ with low gate charge. It can be used in a wide variety of applications.

General Features

- $V_{DS} = 150V, I_D = 12A$
 $R_{DS(ON)} < 160m\Omega @ V_{GS} = 10V$ (Typ: 130m Ω)
- High density cell design for ultra low R_{dson}
- Fully characterized avalanche voltage and current
- Excellent package for good heat dissipation

Application

- Power switching application
- Hard switched and high frequency circuits

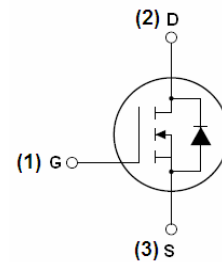
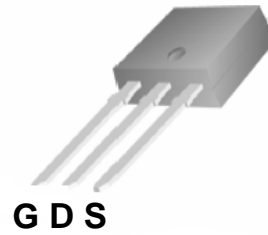

Marking Diagram

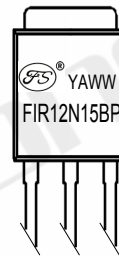

- Y = Year
- A = Assembly Location
- WW = Work Week
- FIR12N15BP = Specific Device Code

Package Marking and Ordering Information

| Device Marking | Device | Device Package | Reel Size | Tape width | Quantity |
|----------------|-------------|----------------|-----------|------------|----------|
| FIR12N15BP | FIR12N15BPG | TO-251 | - | - | - |

Absolute Maximum Ratings ($T_C = 25^\circ C$ unless otherwise noted)

| Parameter | Symbol | Limit | Unit |
|--|----------------|------------|------------|
| Drain-Source Voltage | V_{DS} | 150 | V |
| Gate-Source Voltage | V_{GS} | ± 20 | V |
| Drain Current-Continuous | I_D | 12 | A |
| Drain Current-Pulsed ^(Note 1) | I_{DM} | 50 | A |
| Maximum Power Dissipation | P_D | 55 | W |
| Operating Junction and Storage Temperature Range | T_J, T_{STG} | -55 To 175 | $^\circ C$ |

Thermal Characteristic

| | | | |
|--|-----------------|-----|--------------|
| Thermal Resistance, Junction-to-Case ^(Note 2) | $R_{\theta JC}$ | 2.7 | $^\circ C/W$ |
|--|-----------------|-----|--------------|

**Electrical Characteristics (T_C=25°C unless otherwise noted)**

| Parameter | Symbol | Condition | Min | Typ | Max | Unit |
|---|---------------------|---|-----|-----|------|------|
| Off Characteristics | | | | | | |
| Drain-Source Breakdown Voltage | BV _{DSS} | V _{GS} =0V I _D =250μA | 150 | - | - | V |
| Zero Gate Voltage Drain Current | I _{DSS} | V _{DS} =150V, V _{GS} =0V | - | - | 1 | μA |
| Gate-Body Leakage Current | I _{GSS} | V _{GS} =±20V, V _{DS} =0V | - | - | ±100 | nA |
| On Characteristics (Note 3) | | | | | | |
| Gate Threshold Voltage | V _{GS(th)} | V _{DS} =V _{GS} , I _D =250μA | 1.5 | 2 | 2.5 | V |
| Drain-Source On-State Resistance | R _{DS(on)} | V _{GS} =10V, I _D =5A | - | 130 | 160 | mΩ |
| Forward Transconductance | g _{FS} | V _{DS} =15V, I _D =10A | - | 15 | - | S |
| Dynamic Characteristics (Note4) | | | | | | |
| Input Capacitance | C _{ISS} | V _{DS} =25V, V _{GS} =0V, F=1.0MHz | - | 900 | - | PF |
| Output Capacitance | C _{OSS} | | - | 115 | - | PF |
| Reverse Transfer Capacitance | C _{RSS} | | - | 70 | - | PF |
| Switching Characteristics (Note 4) | | | | | | |
| Turn-on Delay Time | t _{d(on)} | V _{DD} =75V, I _D =1A, R _L =75Ω V _{GS} =10V, R _G =6Ω | - | 8 | - | nS |
| Turn-on Rise Time | t _r | | - | 10 | - | nS |
| Turn-Off Delay Time | t _{d(off)} | | - | 20 | - | nS |
| Turn-Off Fall Time | t _f | | - | 15 | - | nS |
| Total Gate Charge | Q _g | V _{DS} =75V, I _D =1.5A, V _{GS} =10V | - | 19 | - | nC |
| Gate-Source Charge | Q _{gs} | | - | 5.5 | - | nC |
| Gate-Drain Charge | Q _{gd} | | - | 7 | - | nC |
| Drain-Source Diode Characteristics | | | | | | |
| Diode Forward Voltage (Note 3) | V _{SD} | V _{GS} =0V, I _S =2A | - | - | 1.2 | V |
| Diode Forward Current (Note 2) | I _S | | - | - | 12 | A |

Notes:

1. Repetitive Rating: Pulse width limited by maximum junction temperature.
2. Surface Mounted on FR4 Board, t ≤ 10 sec.
3. Pulse Test: Pulse Width ≤ 300μs, Duty Cycle ≤ 2%.
4. Guaranteed by design, not subject to product

Test Circuit

1) E_{AS} Test Circuit

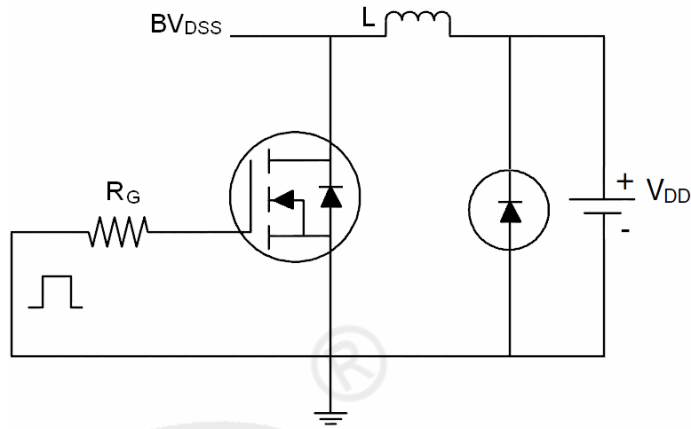

2) Gate Charge Test Circuit

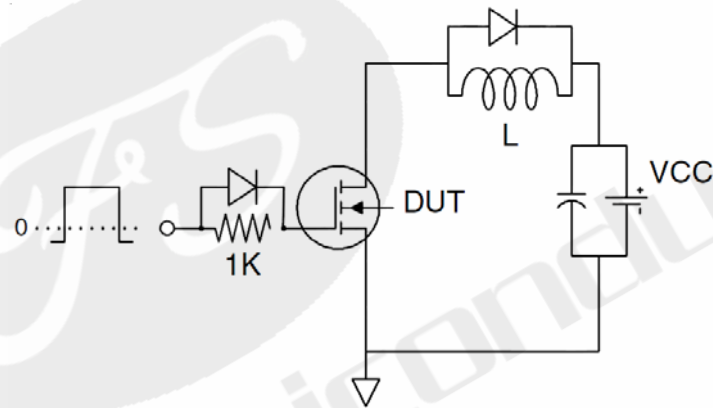

3) Switch Time Test Circuit

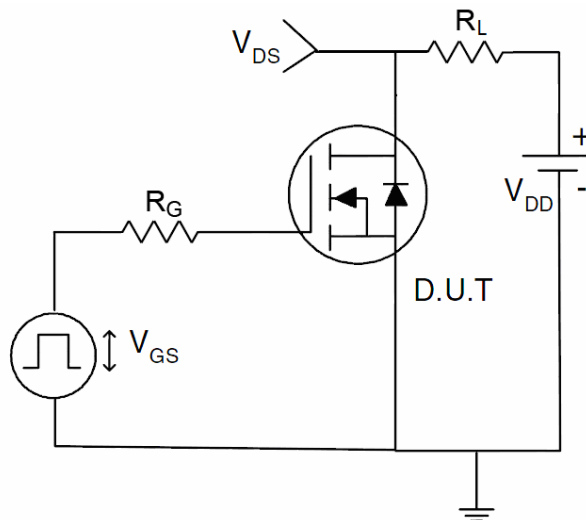



Typical Electrical and Thermal Characteristics (Curves)

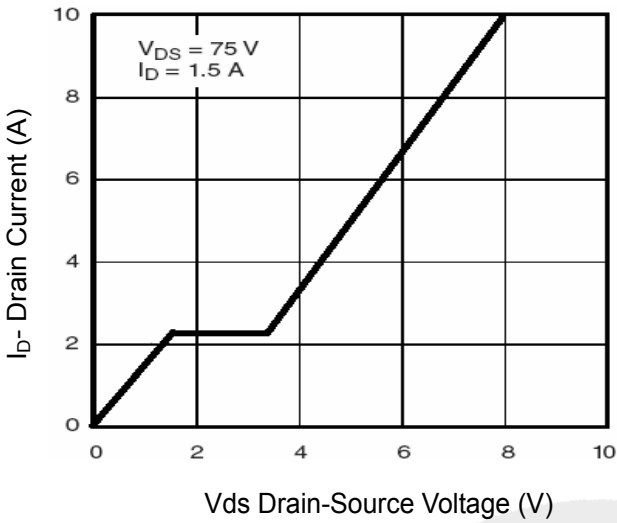

Figure 1 Output Characteristics

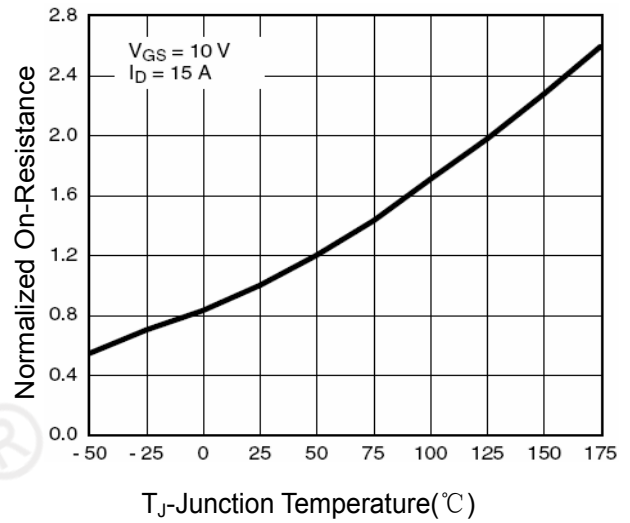

Figure 4 Rdson- Junction Temperature

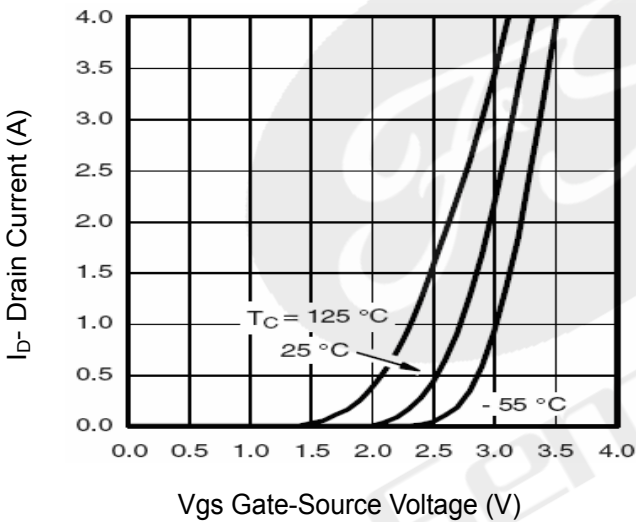

Figure 2 Transfer Characteristics

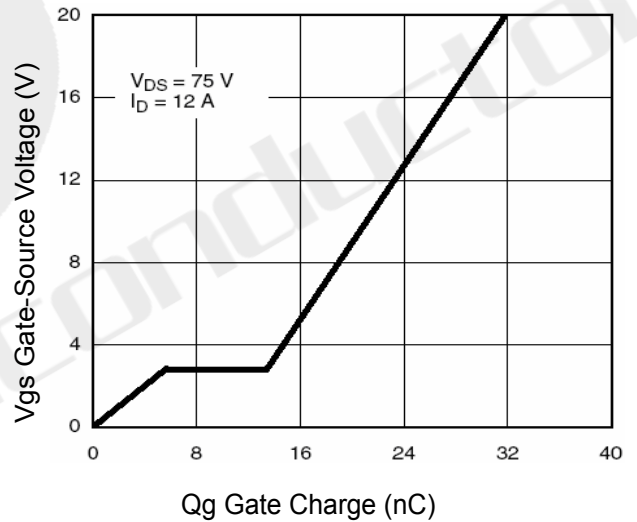

Figure 5 Gate Charge

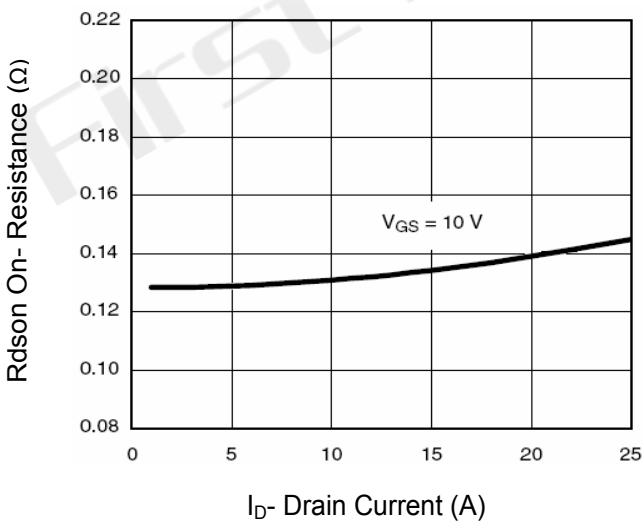

Figure 3 Rdson- Drain Current

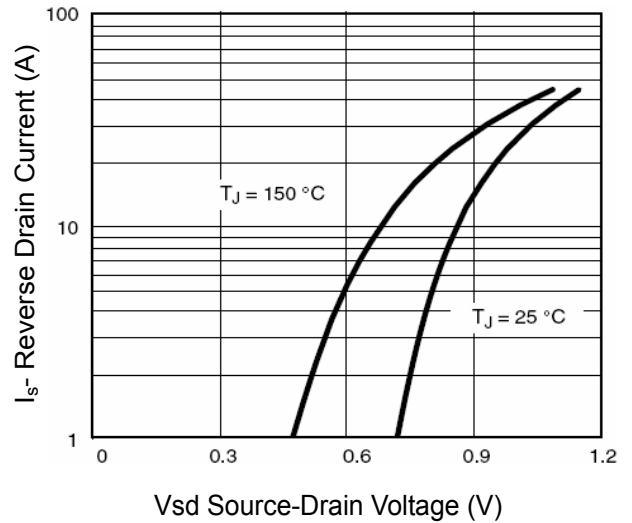

Figure 6 Source- Drain Diode Forward

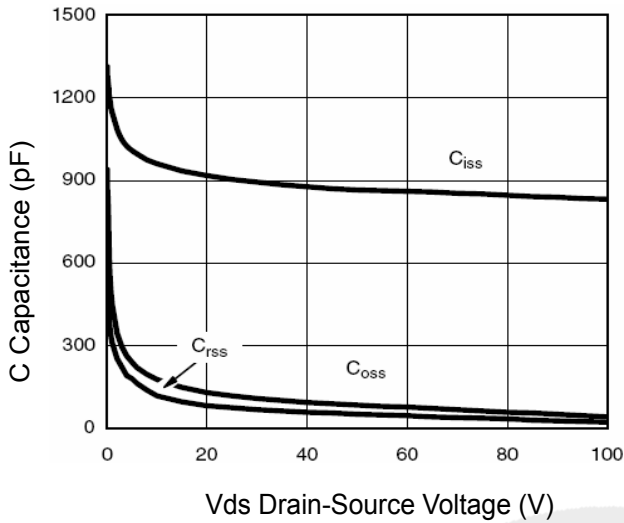

Figure 7 Capacitance vs Vds

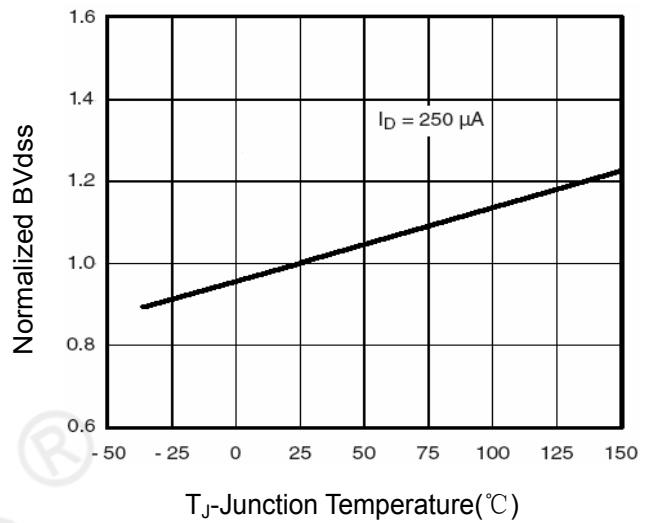

Figure 9 BV_{DSS} vs Junction Temperature

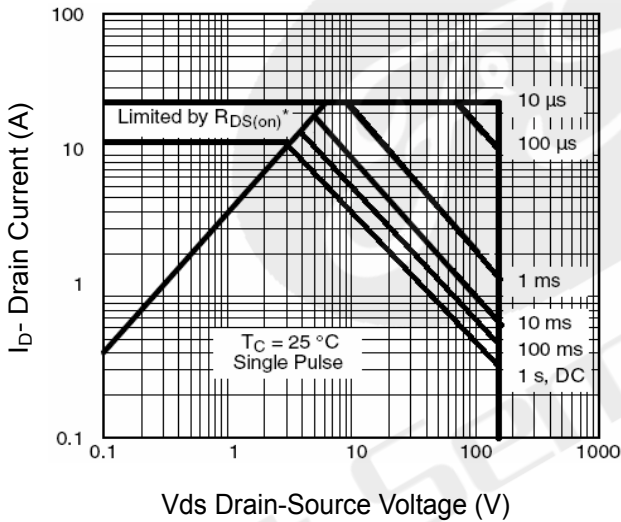

Figure 8 Safe Operation Area

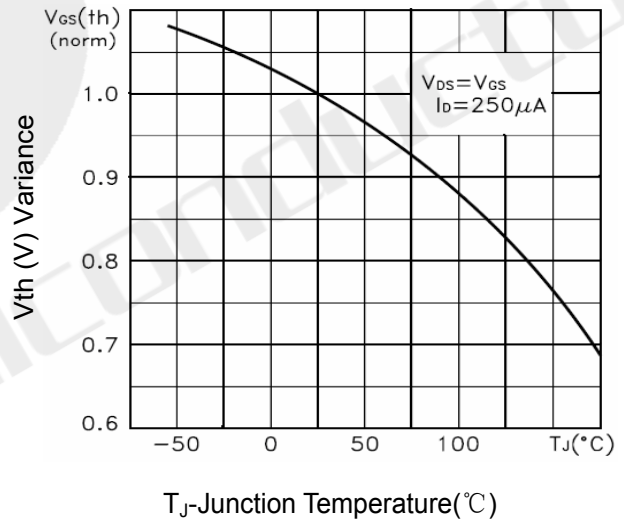

Figure 10 $V_{GS(th)}$ vs Junction Temperature

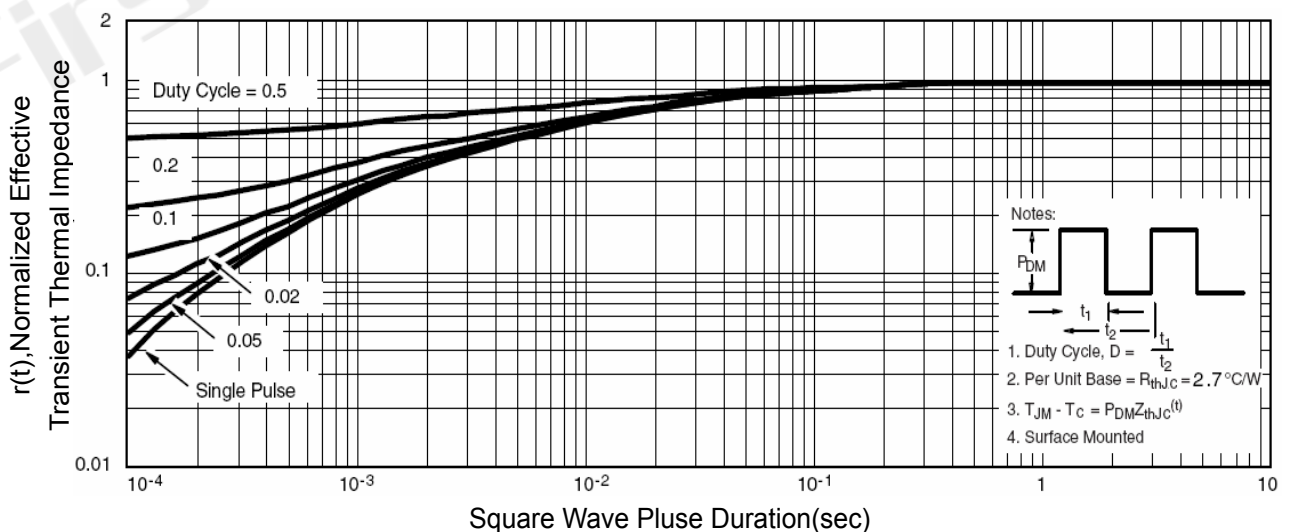
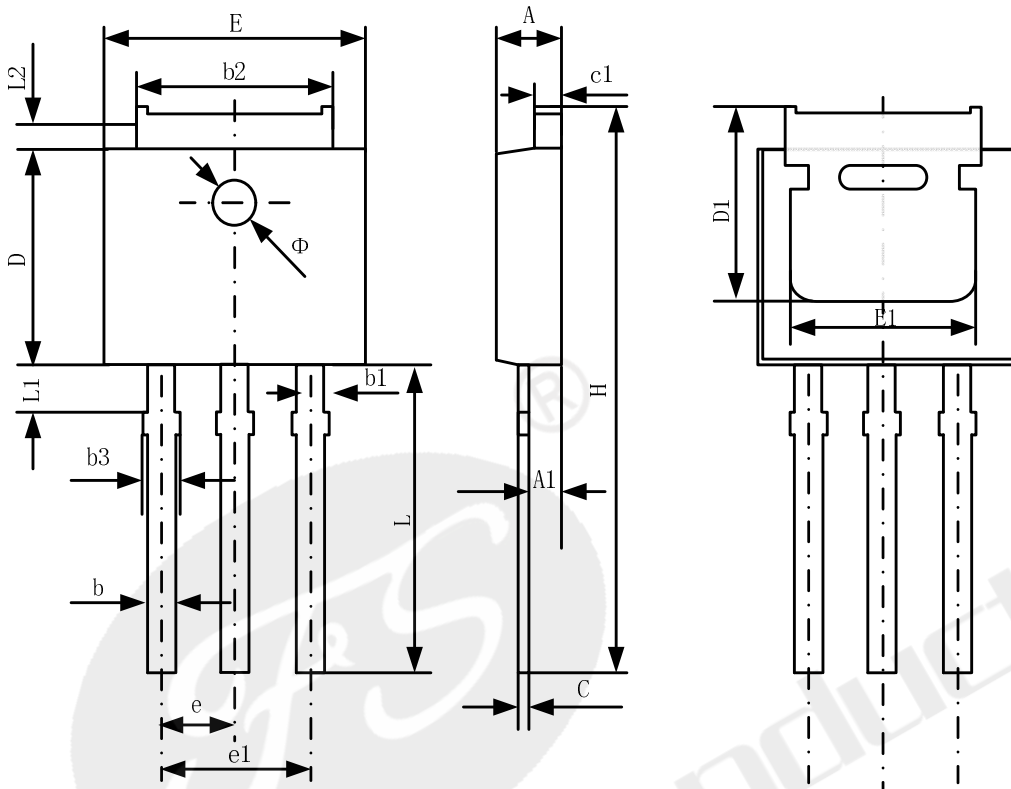

Figure 11 Normalized Maximum Transient Thermal Impedance

Package Information



| Symbol | Dimensions In Millimeters | | Dimensions In Inches | |
|--------|---------------------------|-------|----------------------|-------|
| | Min. | Max. | Min. | Max. |
| A | 2.20 | 2.35 | 0.087 | 0.093 |
| A1 | 0.90 | 1.10 | 0.035 | 0.043 |
| b | 0.56 | 0.69 | 0.022 | 0.027 |
| b1 | 0.77 | 0.90 | 0.030 | 0.035 |
| b2 | 5.23 | 5.43 | 0.206 | 0.214 |
| b3 | | 1.05 | | 0.041 |
| C | 0.46 | 0.59 | 0.018 | 0.023 |
| c1 | 0.46 | 0.59 | 0.018 | 0.023 |
| D | 6.00 | 6.20 | 0.236 | 0.244 |
| D1 | 5.20 | -- | 0.205 | -- |
| E | 6.50 | 6.70 | 0.256 | 0.264 |
| E1 | 4.60 | 5.00 | 0.181 | 0.197 |
| e | 2.24 | 2.34 | 0.088 | 0.092 |
| e1 | 4.47 | 4.67 | 0.176 | 0.184 |
| H | 16.18 | 16.78 | 0.637 | 0.661 |
| L | 9.00 | 9.60 | 0.354 | 0.378 |
| L1 | 0.95 | 1.35 | 0.037 | 0.053 |
| L2 | 0.90 | 1.25 | 0.035 | 0.049 |



Declaration

- FIRST reserves the right to change the specifications, the same specifications of products due to different packaging line mold, the size of the appearance will be slightly different, shipped in kind, without notice! Customers should obtain the latest version information before ordering, and verify whether the relevant information is complete and up-to-date.
- Any semiconductor product under certain conditions has the possibility of failure or failure, The buyer has the responsibility to comply with safety standards and take safety measures when using FIRST products for system design and manufacturing, To avoid To avoid potential failure risks, which may cause personal injury or property damage!
- Product promotion endless, our company will wholeheartedly provide customers with better products!

ATTACHMENT

Revision History

| Date | REV | Description | Page |
|------------|-----|-----------------|------|
| 2018.01.01 | 1.0 | Initial release | |