



PIN Connection TO-220F

V <sub>DSS</sub>	600	V
I <sub>D</sub>	20	A
P <sub>D</sub> (T <sub>C</sub> =25°C)	250	W
R <sub>DS(ON)</sub>	0.35	Ω

Features

- Fast Switching
- Low ON Resistance(R<sub>dson</sub>≤0.45Ω)
- Low Gate Charge (Typical Data:70nC)
- Low Reverse transfer capacitances(Typical: 32pF)
- 100% Single Pulse avalanche energy Test

Applications

Power switch circuit of adaptor and charger.

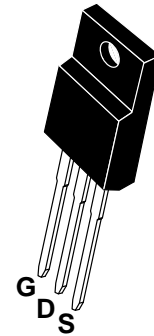

Schematic diagram

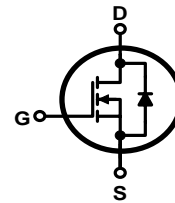

Marking Diagram



Y = Year  
 A = Assembly Location  
 WW = Work Week  
 FIR20N60F = Specific Device Code

Absolute (T<sub>c</sub>= 25°C unless otherwise specified)

Symbol	Parameter	Rating	Units
V <sub>DSS</sub>	Drain-to-Source Voltage	600	V
I <sub>D</sub>	Continuous Drain Current	20	A
	Continuous Drain Current T <sub>C</sub> = 100 °C	13	A
I <sub>DM</sub> <sup>a1</sup>	Pulsed Drain Current	80	A
V <sub>GS</sub>	Gate-to-Source Voltage	±30	V
E <sub>AS</sub> <sup>a2</sup>	Single Pulse Avalanche Energy	1000	mJ
E <sub>AR</sub> <sup>a1</sup>	Avalanche Energy ,Repetitive	100	mJ
I <sub>AR</sub> <sup>a1</sup>	Avalanche Current	14	A
dv/dt <sup>a3</sup>	Peak Diode Recovery dv/dt	4.5	V/ns
P <sub>D</sub>	Power Dissipation	250	W
	Derating Factor above 25°C	2.0	W/°C
T <sub>J</sub> , T <sub>stg</sub>	Operating Junction and Storage Temperature Range	150, -55 to 150	°C
T <sub>L</sub>	Maximum Temperature for Soldering	300	°C



**Electrical Characteristics** (Tc= 25°C unless otherwise specified)

<b>OFF Characteristics</b>						
Symbol	Parameter	Test Conditions	Rating			Units
			Min.	Typ.	Max.	
V <sub>DSS</sub>	Drain to Source Breakdown Voltage	V <sub>GS</sub> =0V, I <sub>D</sub> =250μA	600	--	--	V
ΔBV <sub>DSS</sub> /ΔT <sub>J</sub>	Bvdss Temperature Coefficient	I <sub>D</sub> =250uA, Reference 25°C	--	0.65	--	V/°C
I <sub>DSS</sub>	Drain to Source Leakage Current	V <sub>DS</sub> = 600V, V <sub>GS</sub> = 0V, T <sub>a</sub> = 25°C	--	--	10	μA
		V <sub>DS</sub> =480V, V <sub>GS</sub> = 0V, T <sub>a</sub> = 125°C			200	
I <sub>GSS(F)</sub>	Gate to Source Forward Leakage	V <sub>GS</sub> = 30V	--	--	100	nA
I <sub>GSS(R)</sub>	Gate to Source Reverse Leakage	V <sub>GS</sub> =-30V	--	--	-100	nA

<b>ON Characteristics</b>						
Symbol	Parameter	Test Conditions	Rating			Units
			Min.	Typ.	Max.	
R <sub>DS(ON)</sub>	Drain-to-Source On-Resistance	V <sub>GS</sub> =10V, I <sub>D</sub> =9.0A	--	0.35	0.45	Ω
V <sub>GS(TH)</sub>	Gate Threshold Voltage	V <sub>DS</sub> = V <sub>GS</sub> , I <sub>D</sub> = 250μA	2.0	--	4.0	V
Pulse width tp ≤ 380μs, δ ≤ 2%						

<b>Dynamic Characteristics</b>						
Symbol	Parameter	Test Conditions	Rating			Units
			Min.	Typ.	Max.	
g <sub>fs</sub>	Forward Transconductance	V <sub>DS</sub> =15V, I <sub>D</sub> =9.0A	--	15	--	S
C <sub>iss</sub>	Input Capacitance	V <sub>GS</sub> = 0V V <sub>DS</sub> = 25V f = 1.0MHz	--	2600		pF
C <sub>oss</sub>	Output Capacitance		--	320		
C <sub>rss</sub>	Reverse Transfer Capacitance		--	32		

<b>Resistive Switching Characteristics</b>						
Symbol	Parameter	Test Conditions	Rating			Units
			Min.	Typ.	Max.	
t <sub>d(ON)</sub>	Turn-on Delay Time	I <sub>D</sub> =18A V <sub>DD</sub> = 300V R <sub>G</sub> = 25Ω	--	60		ns
t <sub>r</sub>	Rise Time		--	200		
t <sub>d(OFF)</sub>	Turn-Off Delay Time		--	150		
t <sub>f</sub>	Fall Time		--	130		
Q <sub>g</sub>	Total Gate Charge	I <sub>D</sub> =18A V <sub>DD</sub> =480V V <sub>GS</sub> = 10V	--	70		nC
Q <sub>gs</sub>	Gate to Source Charge		--	16	--	
Q <sub>gd</sub>	Gate to Drain ("Miller")Charge		--	32	--	



Source-Drain Diode Characteristics						
Symbol	Parameter	Test Conditions	Rating			Units
			Min.	Typ.	Max.	
$I_S$	Continuous Source Current (Body Diode)		--	--	20	A
$I_{SM}$	Maximum Pulsed Current (Body Diode)		--	--	80	A
$V_{SD}$	Diode Forward Voltage	$I_S=20A, V_{GS}=0V$	--	--	1.5	V
$t_{rr}$	Reverse Recovery Time	$I_S=20A, T_j = 25^\circ C$	--	400	--	ns
$Q_{rr}$	Reverse Recovery Charge	$di_f/dt=100A/us, V_{GS}=0V$	--	4.5	--	nC
Pulse width $t_p \leq 380\mu s, \delta \leq 2\%$						

Symbol	Parameter	Typ.	Units
$R_{\theta JC}$	Junction-to-Case	0.5	$^\circ C/W$
$R_{\theta JA}$	Junction-to-Ambient	120	$^\circ C/W$

<sup>a1</sup>: Repetitive rating; pulse width limited by maximum junction temperature

<sup>a2</sup>:  $L=10mH, I_D=20A, \text{Start } T_j=25^\circ C$

<sup>a3</sup>:  $I_{SD}=20A, di/dt \leq 200A/us, V_{DD} \leq BV_{DSS}, \text{Start } T_j=25^\circ C$



Characteristic Curves

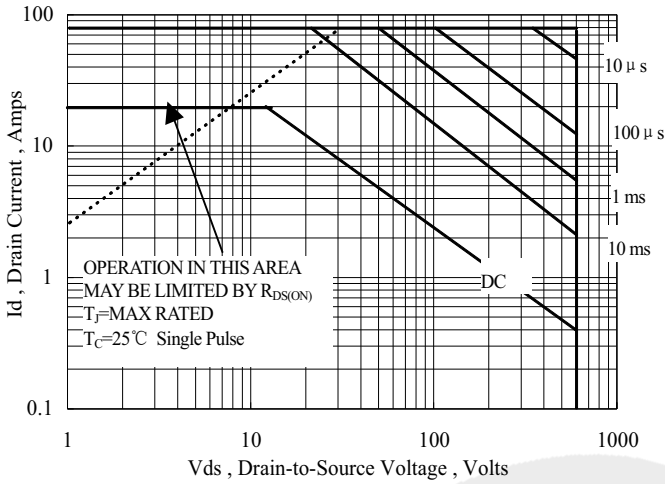

Figure 1 Maximum Forward Bias Safe Operating Area

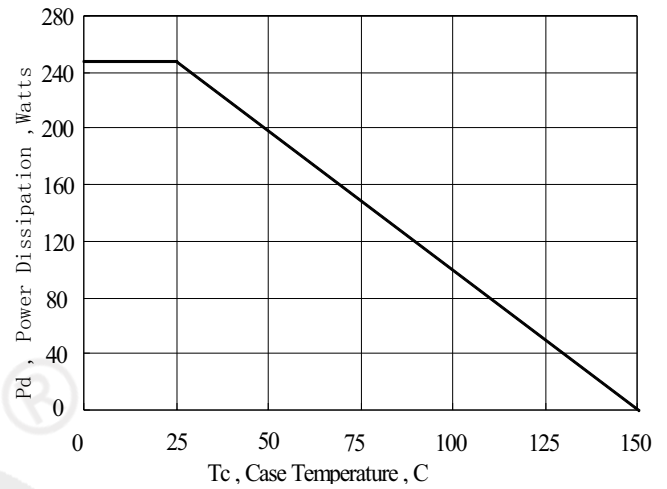

Figure 2 Maximum Power Dissipation vs Case Temperature

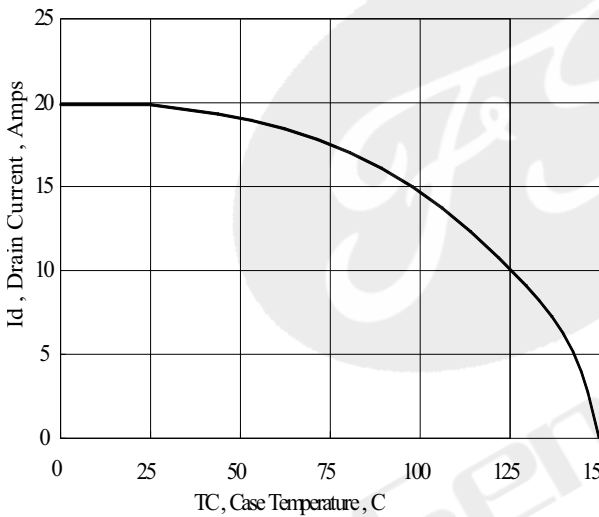

Figure 3 Maximum Continuous Drain Current vs Case Temperature

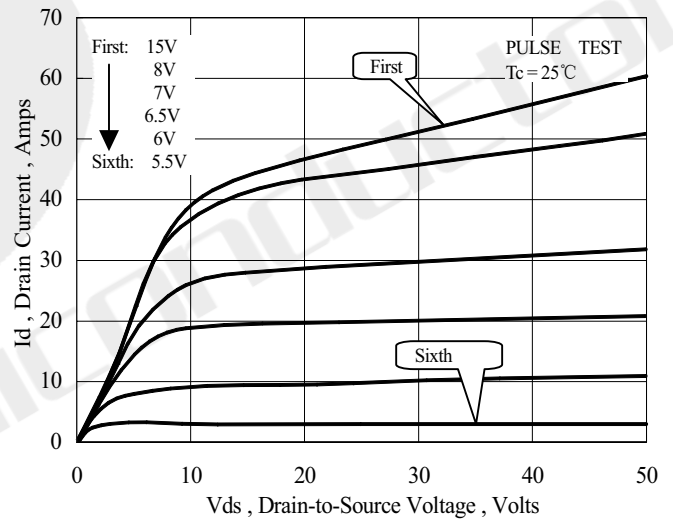

Figure 4 Typical Output Characteristics

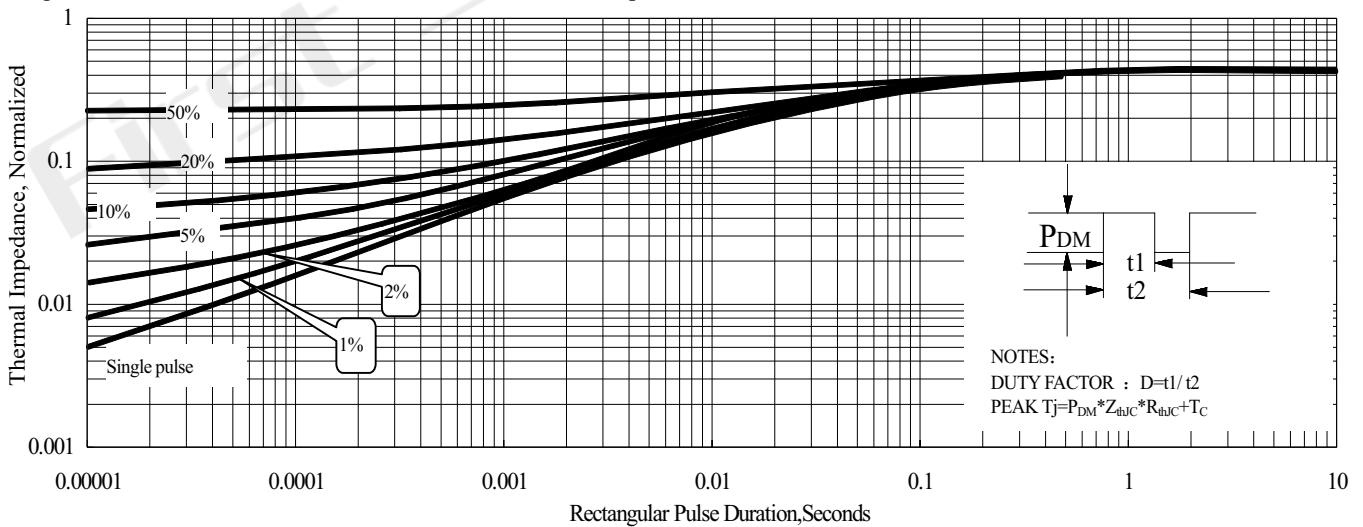

Figure 5 Maximum Effective Thermal Impedance, Junction to Case

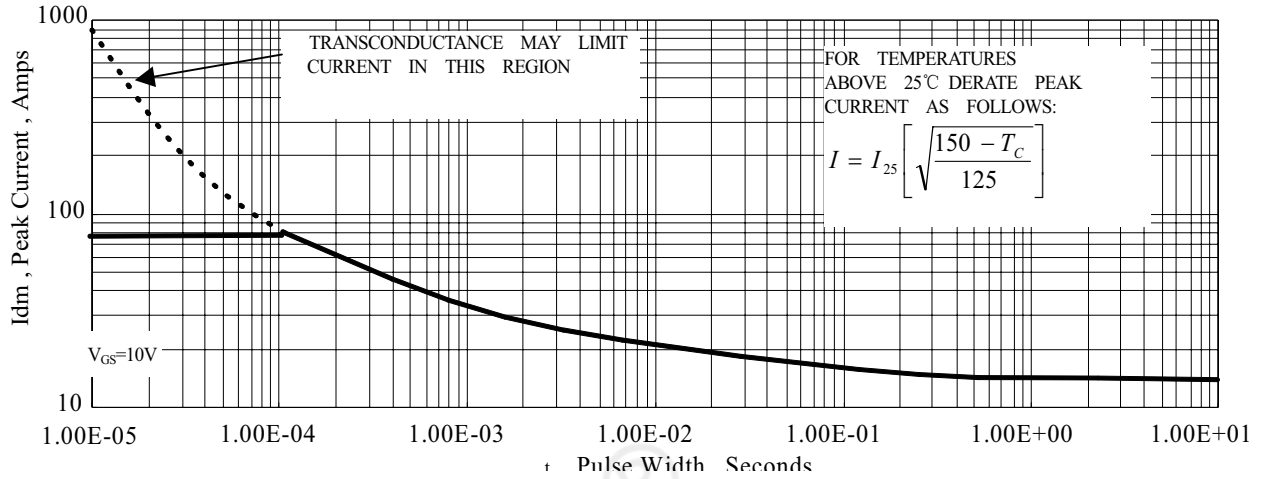

Figure 6 Maximum Peak Current Capability

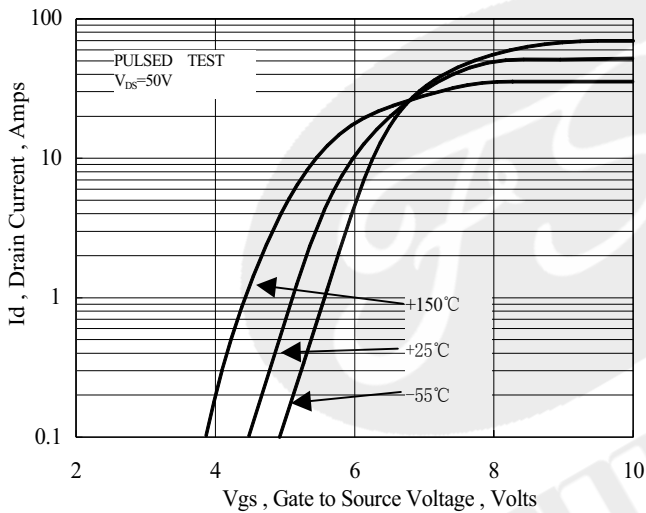

Figure 7 Typical Transfer Characteristics

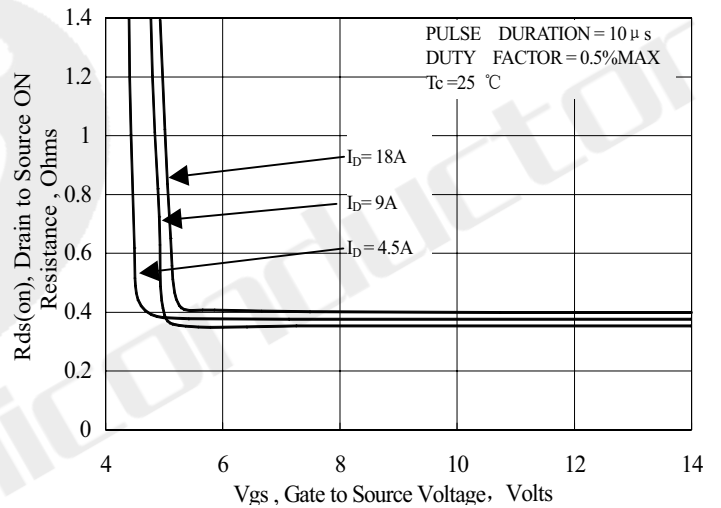

Figure 8 Typical Drain to Source ON Resistance vs Gate Voltage and Drain Current

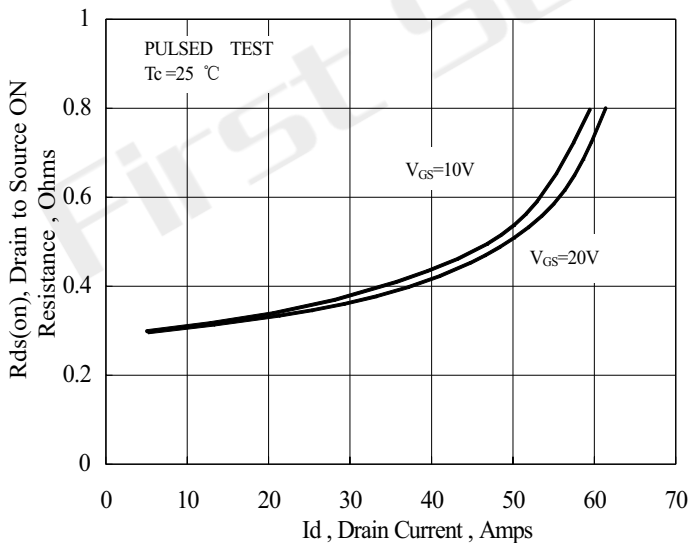

Figure 9 Typical Drain to Source ON Resistance vs Drain Current

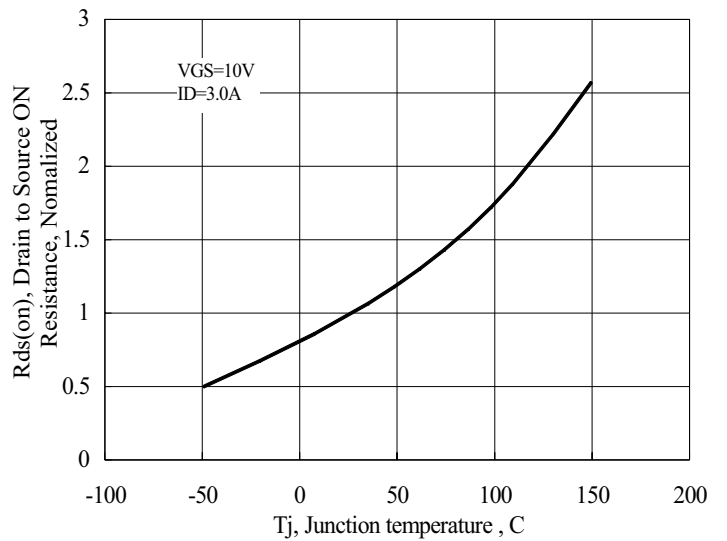

Figure 10 Typical Drain to Source on Resistance vs Junction Temperature

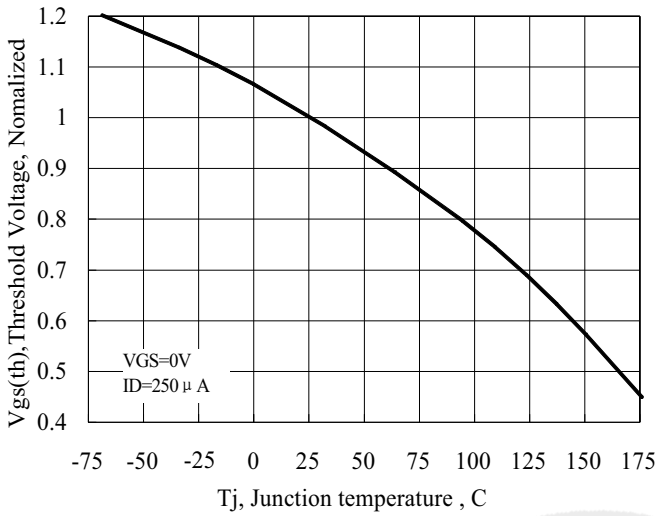

Figure 11 Typical Theshold Voltage vs Junction Temperature

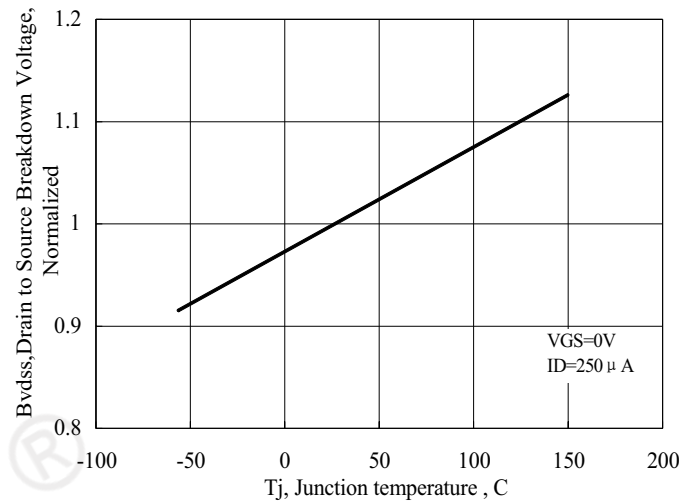

Figure 12 Typical Breakdown Voltage vs Junction Temperature

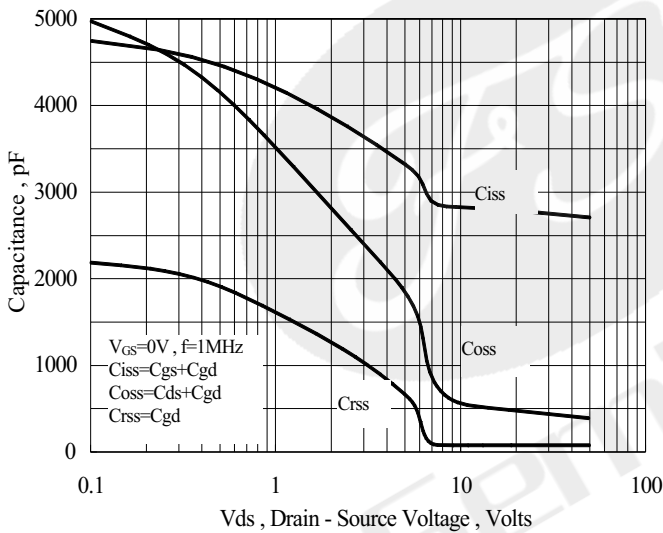

Figure 13 Typical Capacitance vs Drain to Source Voltage

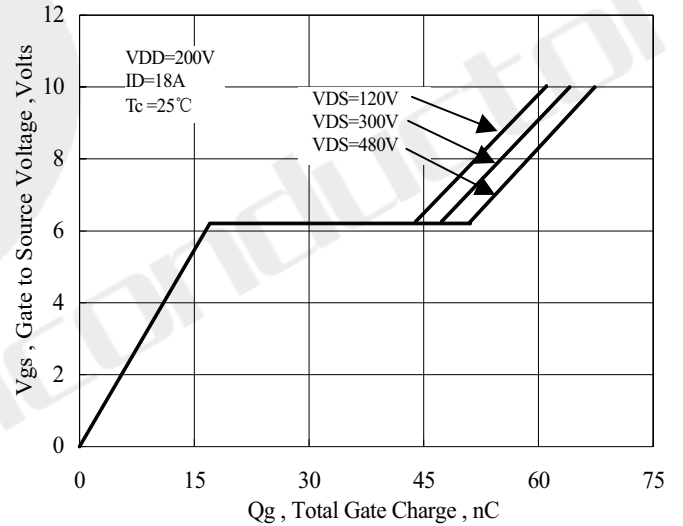

Figure 14 Typical Gate Charge vs Gate to Source Voltage

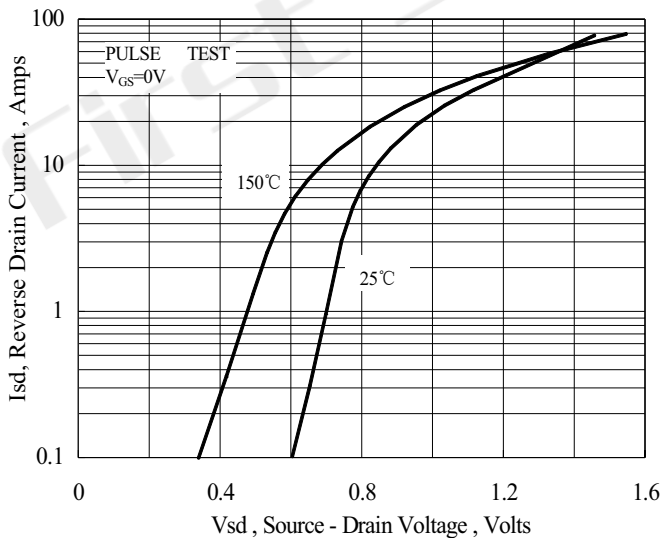

Figure 15 Typical Body Diode Transfer Characteristics

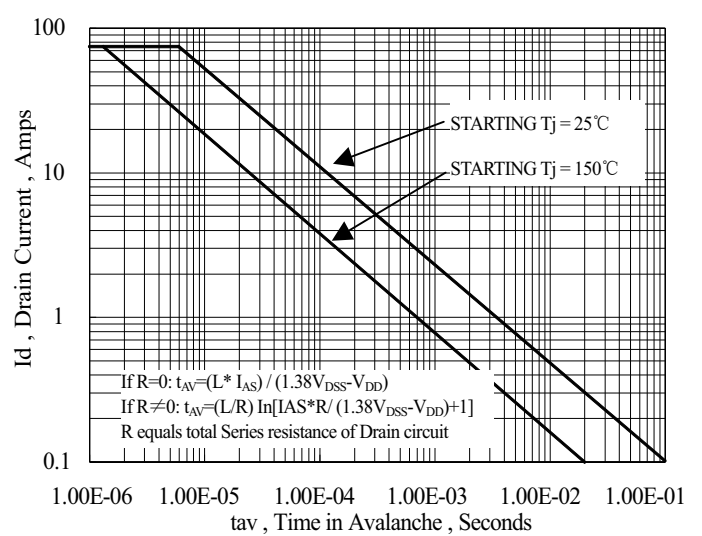
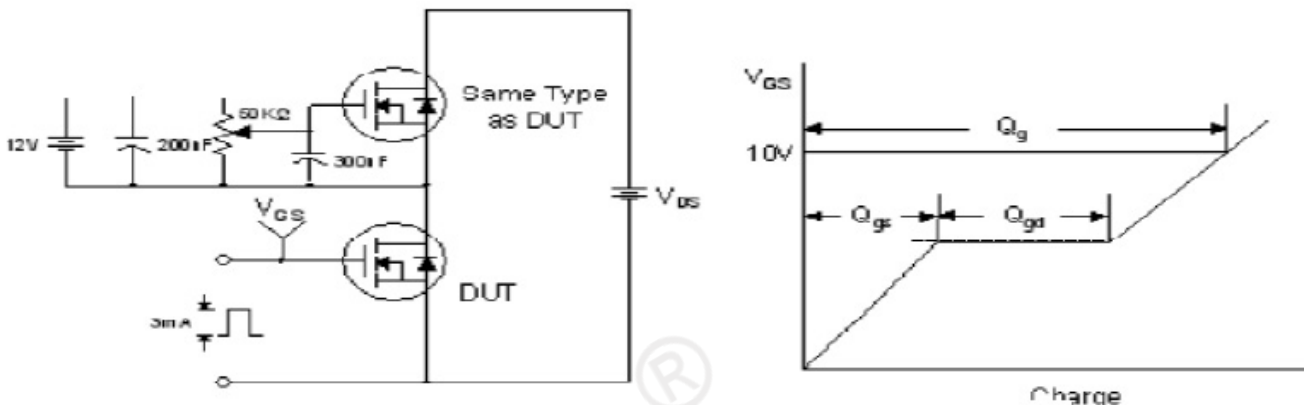

Figure 16 Unclamped Inductive Switching Capability

Test Circuit and Waveform



Gate Charge Test Circuit and Waveform



Resistive Switching Test Circuit and Waveform

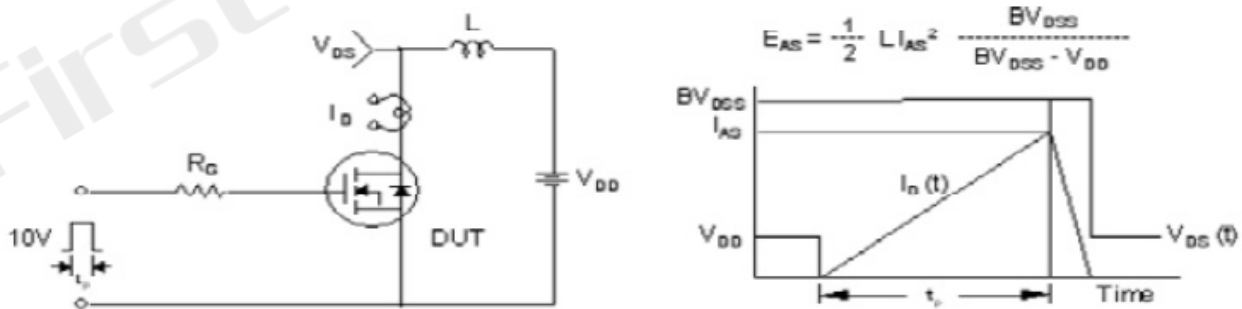

Unclamped Inductive Switching Test Circuit and Waveform

$$E_{AS} = \frac{1}{2} L I_{AS}^2 \frac{BV_{DSS}}{BV_{DSS} - V_{D0}}$$

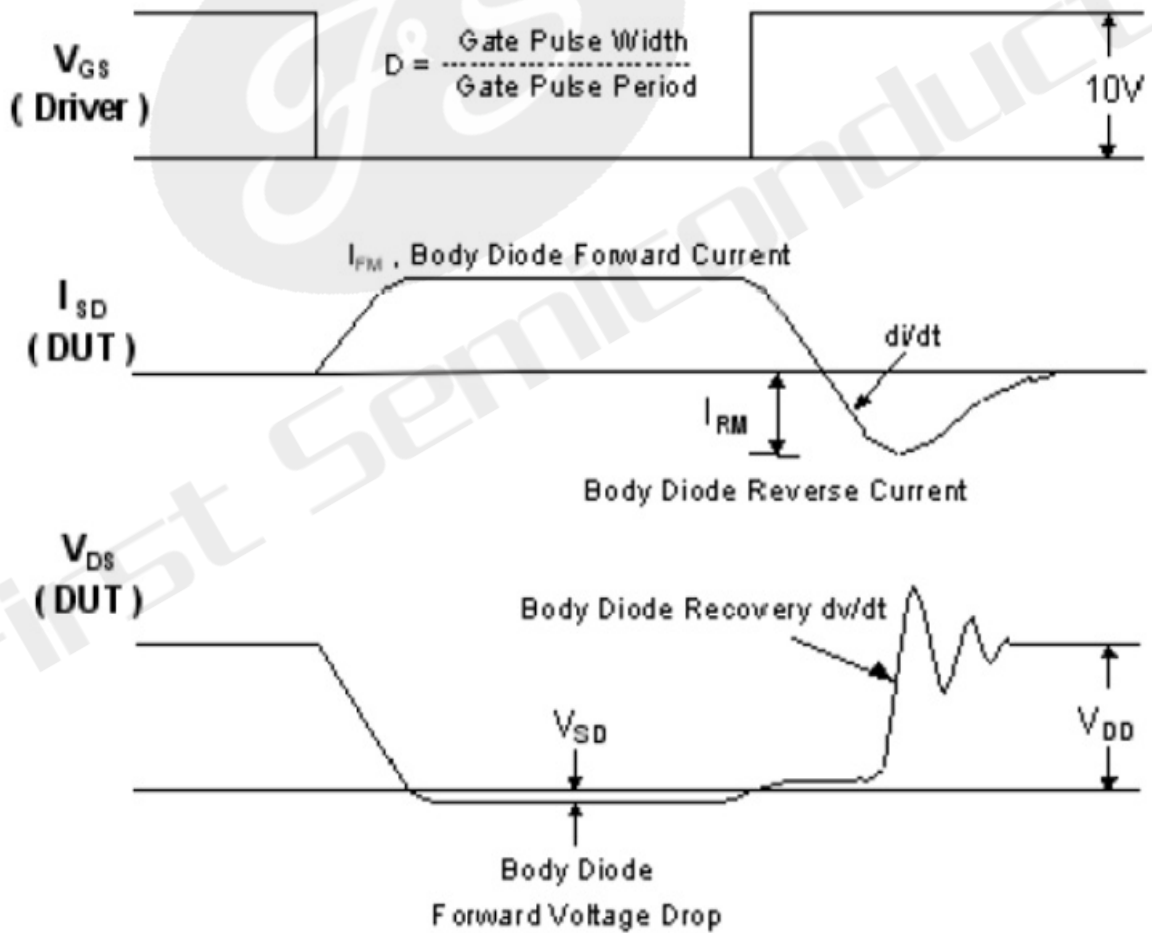
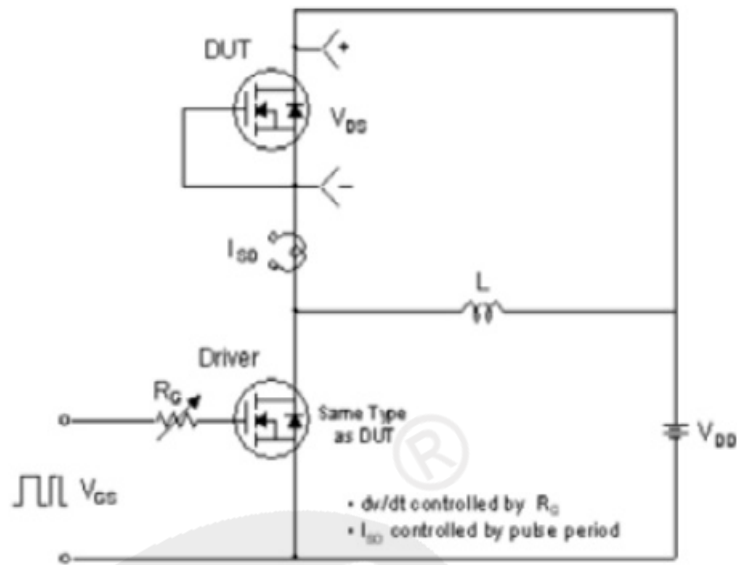

Diode Reverse Recovery Test Circuit and Waveform





## Package Dimensions

### TO-220F

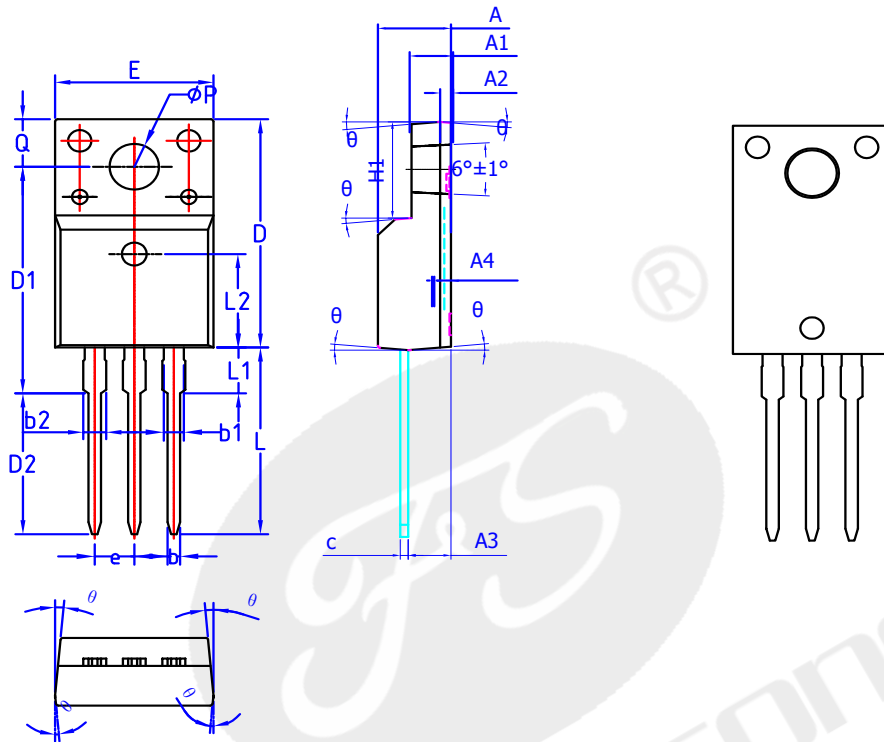

Units: mm

COMMON DIMENSIONS  
(UNITS OF MEASURE=MILLIMETER)

SYMBOL	MIN	NOM	MAX
A	4.50	4.70	4.90
A1	2.34	2.54	2.74
A2	0.70 REF		
A3	2.56	2.76	2.96
b	0.70	0.80	0.90
b1	1.17	1.2	1.25
b2	1.17	1.2	1.25
c	0.45	0.50	0.60
D	15.67	15.87	16.07
D1	15.55	15.75	15.95
D2	10.0	10.2	10.4
E	9.96	10.16	10.36
e	2.54BSC		
H1	6.48	6.68	6.88
L	12.68	12.98	13.28
L1	-	-	3.50
L2	6.50REF		
phi P	3.08	3.18	3.28
Q	3.20	3.30	3.40
phi 1	1°	3°	5°
A4	0.53	0.56	0.59



Declaration

- FIRST reserves the right to change the specifications, the same specifications of products due to different packaging line mold, the size of the appearance will be slightly different, shipped in kind, without notice! Customers should obtain the latest version information before ordering, and verify whether the relevant information is complete and up-to-date.
- Any semiconductor product under certain conditions has the possibility of failure or failure, The buyer has the responsibility to comply with safety standards and take safety measures when using FIRST products for system design and manufacturing, To avoid To avoid potential failure risks, which may cause personal injury or property damage!
- Product promotion endless, our company will wholeheartedly provide customers with better products!

**ATTACHMENT**

Revision History

Date	REV	Description	Page
2018.01.01	1.0	Initial release	