



**Dual N-channel 20V, SOT-26 MOSFET 双 N-溝道場效應管**

**■ Features 特點**

Low on-resistance and maximum DC current capability 低導通電阻和最大直流電流能力

Super high density cell design 超高元胞密度設計

$R_{DS(ON)} \leq 35m\Omega @ V_{GS}=4.5V$

$R_{DS(ON)} \leq 48m\Omega @ V_{GS}=2.5V$

**■ Applications 應用**

Power Management in Note book 筆記本電源管理

Portable Equipment 便攜式設備

Battery Powered System 電池電源系統

DC/DC Converter 直流/直流變換

Load Switch 負載開關應用

**■ Internal Schematic Diagram 內部結構**

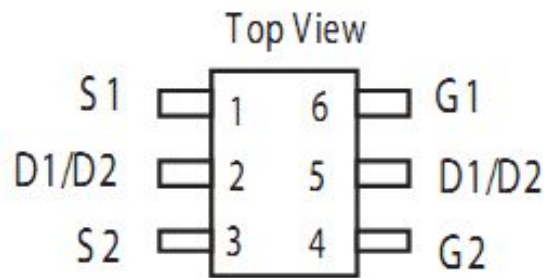
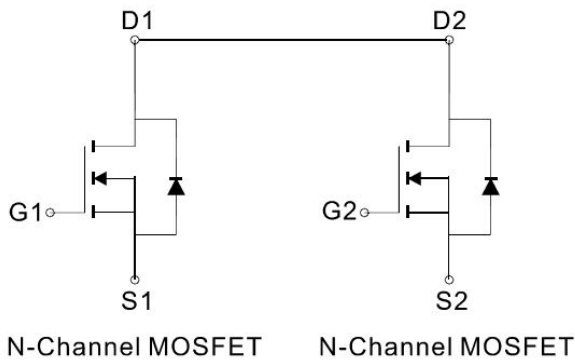

**■ Absolute Maximum Ratings 最大額定值**

Characteristic 特性參數	Symbol 符號	Max 最大值	Unit 單位
Drain-Source Voltage 漏極-源極電壓	$BV_{DSS}$	20	V
Gate- Source Voltage 柵極-源極電壓	$V_{GS}$	$\pm 8$	V
Drain Current (continuous) 漏極電流-連續	$I_D$	5.0	A
Drain Current (pulsed) 漏極電流-脈沖	$I_{DM}$	20	A
Total Device Dissipation 總耗散功率	$P_{TOT}$	1.25	W
Thermal Resistance Junction-Ambient 熱阻	$R_{\theta JA}$	100	$^{\circ}C/W$
Junction/Storage Temperature 結溫/儲存溫度	$T_J, T_{stg}$	-55~150	$^{\circ}C$



■ **Electrical Characteristics 電特性**

( $T_A=25^{\circ}\text{C}$  unless otherwise noted 如無特殊說明，溫度為  $25^{\circ}\text{C}$ )

Characteristic 特性參數	Symbol 符號	Min 最小值	Typ 典型值	Max 最大值	Unit 單位
Drain-Source Breakdown Voltage 漏極-源極擊穿電壓( $I_D=250\mu\text{A}, V_{GS}=0\text{V}$ )	$BV_{DSS}$	20	—	—	V
Gate Threshold Voltage 柵極開啓電壓( $I_D=250\mu\text{A}, V_{GS}=V_{DS}$ )	$V_{GS(th)}$	0.5	—	1.0	V
Zero Gate Voltage Drain Current 零柵壓漏極電流( $V_{GS}=0\text{V}, V_{DS}=20\text{V}$ )	$I_{DSS}$	—	—	1	$\mu\text{A}$
Gate Body Leakage 柵極漏電流( $V_{GS}=\pm 8\text{V}, V_{DS}=0\text{V}$ )	$I_{GSS}$	—	—	$\pm 100$	nA
Static Drain-Source On-State Resistance 靜態漏源導通電阻( $I_D=5\text{A}, V_{GS}=4.5\text{V}$ ) ( $I_D=4\text{A}, V_{GS}=2.5\text{V}$ )	$R_{DS(ON)}$	—	—	35 48	$\text{m}\Omega$
Diode Forward Voltage Drop 內附二極管正向壓降( $I_{SD}=1.7\text{A}, V_{GS}=0\text{V}$ )	$V_{SD}$	—	—	1.2	V
Input Capacitance 輸入電容 ( $V_{GS}=0\text{V}, V_{DS}=10\text{V}, f=1\text{MHz}$ )	$C_{ISS}$	—	800	—	pF
Common Source Output Capacitance 共源輸出電容( $V_{GS}=0\text{V}, V_{DS}=10\text{V}, f=1\text{MHz}$ )	$C_{OSS}$	—	155	—	pF
Reverse Transfer Capacitance 反向傳輸電容 ( $V_{GS}=0\text{V}, V_{DS}=10\text{V}, f=1\text{MHz}$ )	$C_{RSS}$	—	125	—	pF
Gate Source Charge 柵源電荷密度 ( $V_{DS}=10\text{V}, I_D=3\text{A}, V_{GS}=4.5\text{V}$ )	$Q_{gs}$	—	1.2	—	nC
Gate Drain Charge 柵漏電荷密度 ( $V_{DS}=10\text{V}, I_D=3\text{A}, V_{GS}=4.5\text{V}$ )	$Q_{gd}$	—	1.9	—	nC
Turn-On Delay Time 開啓延遲時間 ( $V_{DS}=10\text{V}, I_D=1\text{A}, R_{GEN}=6\Omega, V_{GS}=4.5\text{V}$ )	$t_{d(on)}$	—	8	—	ns
Turn-On Rise Time 開啓上升時間 ( $V_{DS}=10\text{V}, I_D=1\text{A}, R_{GEN}=6\Omega, V_{GS}=4.5\text{V}$ )	$t_r$	—	10	—	ns
Turn-Off Delay Time 關斷延遲時間 ( $V_{DS}=10\text{V}, I_D=1\text{A}, R_{GEN}=6\Omega, V_{GS}=4.5\text{V}$ )	$t_{d(off)}$	—	18	—	ns
Turn-On Fall Time 開啓下降時間 ( $V_{DS}=10\text{V}, I_D=1\text{A}, R_{GEN}=6\Omega, V_{GS}=4.5\text{V}$ )	$t_f$	—	5	—	ns



■ DIMENSION 外形封装尺寸

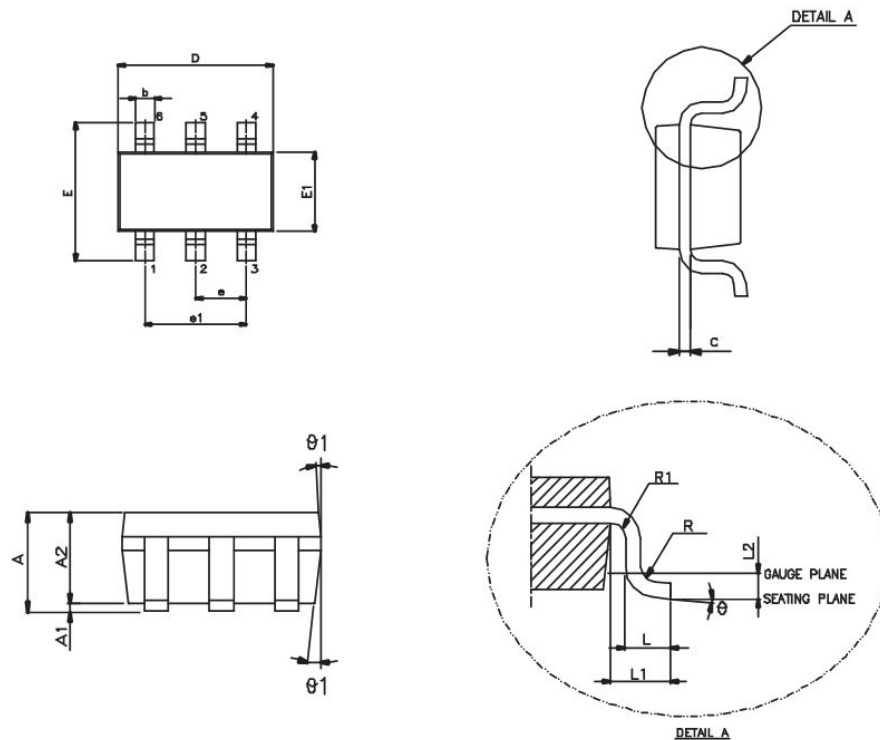

SYMBOL	MIN.	NOM.	MAX.
A	—	—	1.45
A1	—	—	0.15
A2	0.90	1.15	1.30
b	0.30	—	0.50
c	0.08	—	0.22
D	2.90 BSC.		
E	2.80 BSC.		
E1	1.60 BSC.		
e	0.95 BSC		
e1	1.90 BSC.		
L	0.30	0.45	0.60
L1	0.60 REF.		
L2	0.25 BSC.		
R	0.10	—	—
R1	0.10	—	0.25
$\theta$	0°	4°	8°
$\theta 1$	5°	10°	15°