

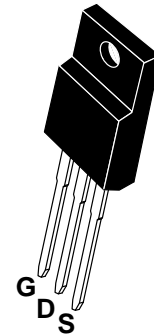

PIN Connection TO-220F

V _{DSS}	600	V
I _D	2	A
P _D (T _C =25°C)	35	W
R _{DS(ON)}	4.5	Ω



Schematic diagram

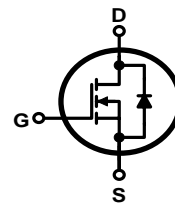

Marking Diagram



Y = Year
 A = Assembly Location
 WW = Work Week
 FIR2N60AF = Specific Device Code

Features

- Fast Switching
- Low ON Resistance
- Low Gate Charge
- Low Reverse transfer capacitances
- 100% Single Pulse avalanche energy Test

Applications

Power switch circuit of adaptor and charger.

Absolute (T_c= 25°C unless otherwise specified)

Symbol	Parameter	Rating	Units
V _{DSS}	Drain-to-Source Voltage	600	V
I _D	Continuous Drain Current	2.0	A
	Continuous Drain Current T _C = 100 °C	1.26	A
I _{DM} ^{a1}	Pulsed Drain Current	8.0	A
V _{GS}	Gate-to-Source Voltage	± 30	V
E _{AS} ^{a2}	Single Pulse Avalanche Energy	100	mJ
E _{AR} ^{a1}	Avalanche Energy ,Repetitive	6.4	mJ
I _{AR} ^{a1}	Avalanche Current	3.6	A
dv/dt ^{a3}	Peak Diode Recovery dv/dt	5	V/ns
P _D	Power Dissipation	35	W
	Derating Factor above 25°C	0.28	W/°C
T _J , T _{stg}	Operating Junction and Storage Temperature Range	150, -55 to 150	°C
T _L	Maximum Temperature for Soldering	300	°C



Electrical Characteristics (Tc= 25°C unless otherwise specified)

OFF Characteristics						
Symbol	Parameter	Test Conditions	Rating			Units
			Min.	Typ.	Max.	
V _{DSS}	Drain to Source Breakdown Voltage	V _{GS} =0V, I _D =250μA	600	--	--	V
ΔBV _{DSS} /ΔT _J	Bvdss Temperature Coefficient	I _D =250uA, Reference 25°C	--	0.7	--	V/°C
I _{DSS}	Drain to Source Leakage Current	V _{DS} = 600V, V _{GS} = 0V, T _a = 25°C	--	--	25	μA
		V _{DS} = 480V, V _{GS} = 0V, T _a = 125°C			250	
I _{GSS(F)}	Gate to Source Forward Leakage	V _{DS} = 0V, V _{GS} = 30V	--	--	100	nA
I _{GSS(R)}	Gate to Source Reverse Leakage	V _{GS} = -30V	--	--	-100	nA

ON Characteristics						
Symbol	Parameter	Test Conditions	Rating			Units
			Min.	Typ.	Max.	
R _{DS(ON)}	Drain-to-Source On-Resistance	V _{GS} =10V, I _D =1.0A	--	3.74	4.5	Ω
V _{GS(TH)}	Gate Threshold Voltage	V _{DS} = V _{GS} , I _D = 250μA	2.0	3.0	4.0	V
Pulse width tp ≤ 380μs, δ ≤ 2%						

Dynamic Characteristics						
Symbol	Parameter	Test Conditions	Rating			Units
			Min.	Typ.	Max.	
g _{fs}	Forward Transconductance	V _{DS} =15V, I _D = 1.0A	2.0	--	--	S
C _{iss}	Input Capacitance	V _{GS} = 0V V _{DS} = 25V f = 1.0MHz	--	280	--	pF
C _{oss}	Output Capacitance		--	30	--	
C _{rss}	Reverse Transfer Capacitance		--	3.8	--	

Resistive Switching Characteristics						
Symbol	Parameter	Test Conditions	Rating			Units
			Min.	Typ.	Max.	
t _{d(ON)}	Turn-on Delay Time	I _D = 2.0A V _{DD} = 300V V _{GS} = 10V R _G = 18Ω	--	7.8	--	ns
t _r	Rise Time		--	5.5	--	
t _{d(OFF)}	Turn-Off Delay Time		--	33	--	
t _f	Fall Time		--	16	--	
Q _g	Total Gate Charge	I _D = 2.0A V _{DD} = 480V V _{GS} = 10V	--	8.5	--	nC
Q _{gs}	Gate to Source Charge		--	1.5	--	
Q _{gd}	Gate to Drain ("Miller") Charge		--	4.0	--	



Source-Drain Diode Characteristics						
Symbol	Parameter	Test Conditions	Rating			Units
			Min.	Typ.	Max.	
I_S	Continuous Source Current (Body Diode)		--	--	2	A
I_{SM}	Maximum Pulsed Current (Body Diode)		--	--	8	A
V_{SD}	Diode Forward Voltage	$I_S=2.0A, V_{GS}=0V$	--	--	1.5	V
t_{rr}	Reverse Recovery Time	$I_S=2.0A, T_j = 25^\circ C$ $dI_F/dt=100A/us,$ $V_{GS}=0V$	--	285	--	ns
Q_{rr}	Reverse Recovery Charge		--	750	--	nC
I_{RRM}	Reverse Recovery Current		--	5.2	--	A
Pulse width $t_p \leq 380\mu s, \delta \leq 2\%$						

Symbol	Parameter	Typ.	Units
$R_{\theta JC}$	Junction-to-Case	3.57	$^\circ C/W$
$R_{\theta JA}$	Junction-to-Ambient	120	$^\circ C/W$

^{a1}: Repetitive rating; pulse width limited by maximum junction temperature

^{a2}: $L=10.0mH, I_D=2A, Start T_j=25^\circ C$

^{a3}: $I_{SD}=2A, di/dt \leq 100A/us, V_{DD} \leq BV_{DS}, Start T_j=25^\circ C$



Characteristic Curves

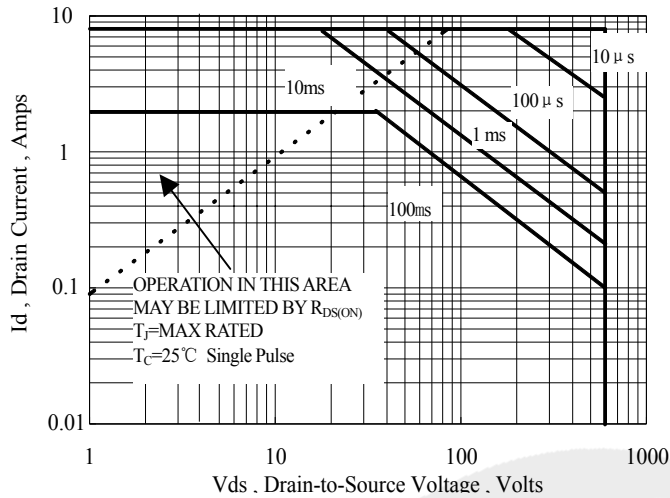

Figure 1 Maximum Forward Bias Safe Operating Area

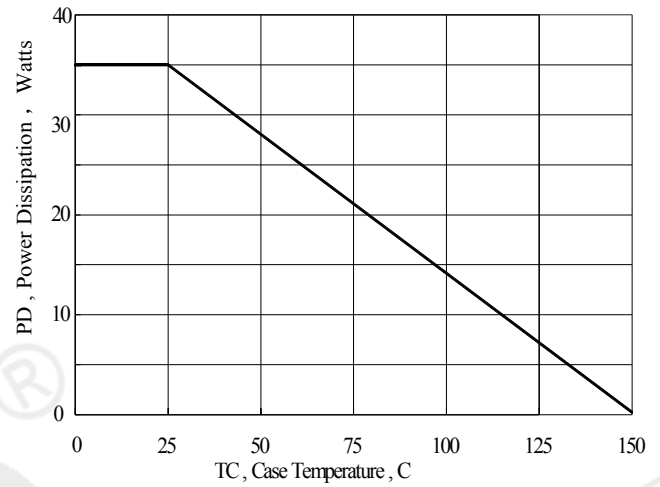

Figure 2 Maximum Power Dissipation vs Case Temperature

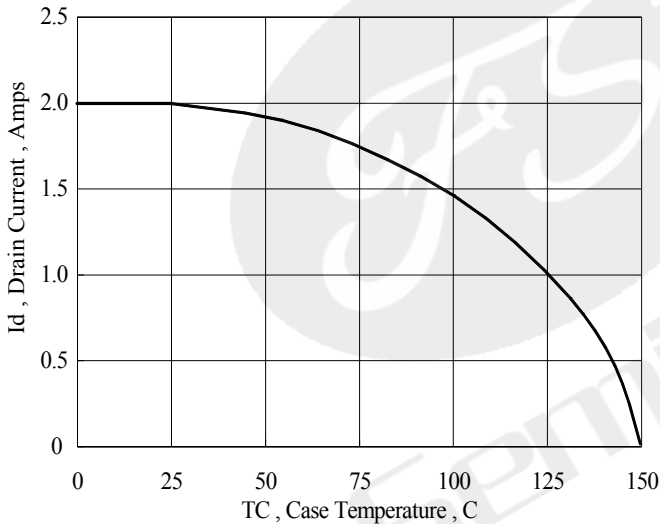

Figure 3 Maximum Continuous Drain Current vs Case Temperature

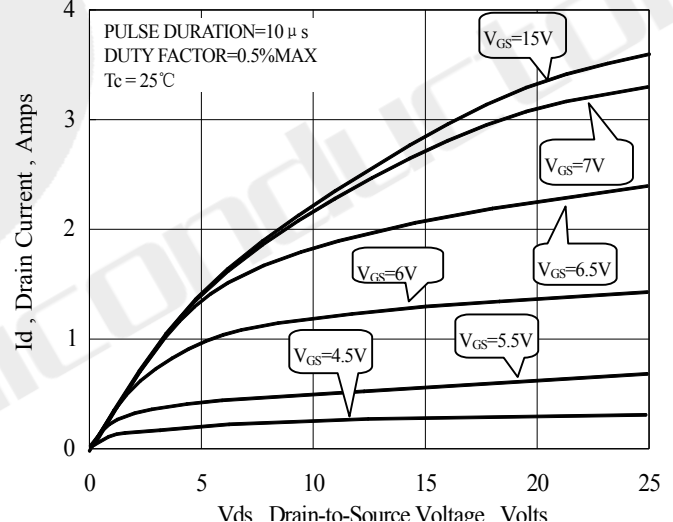

Figure 4 Typical Output Characteristics

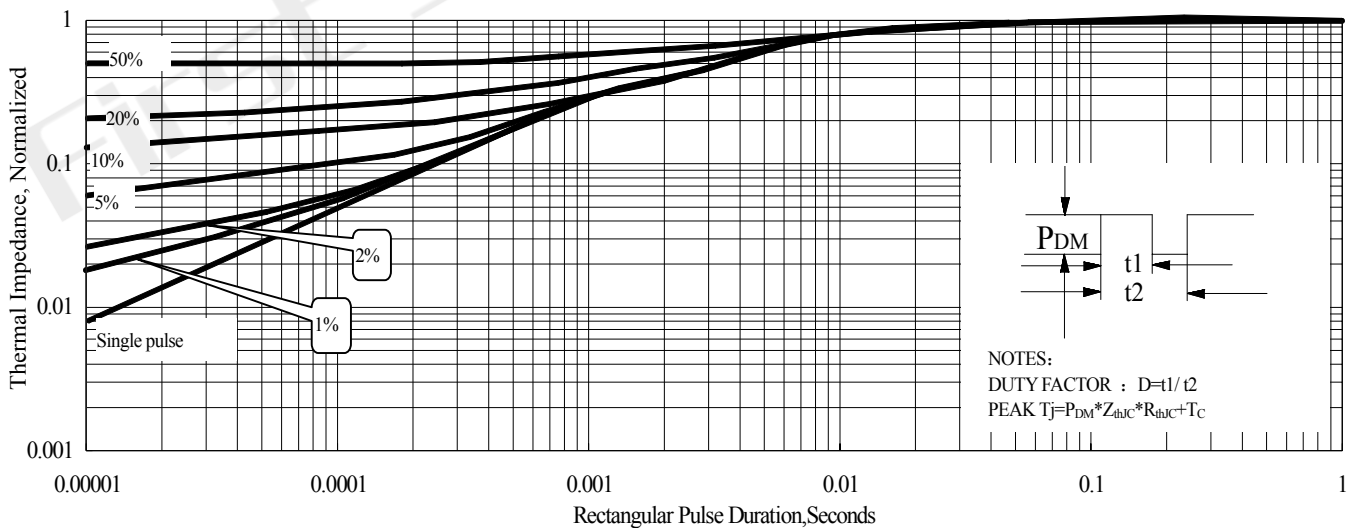

Figure 5 Maximum Effective Thermal Impedance, Junction to Case

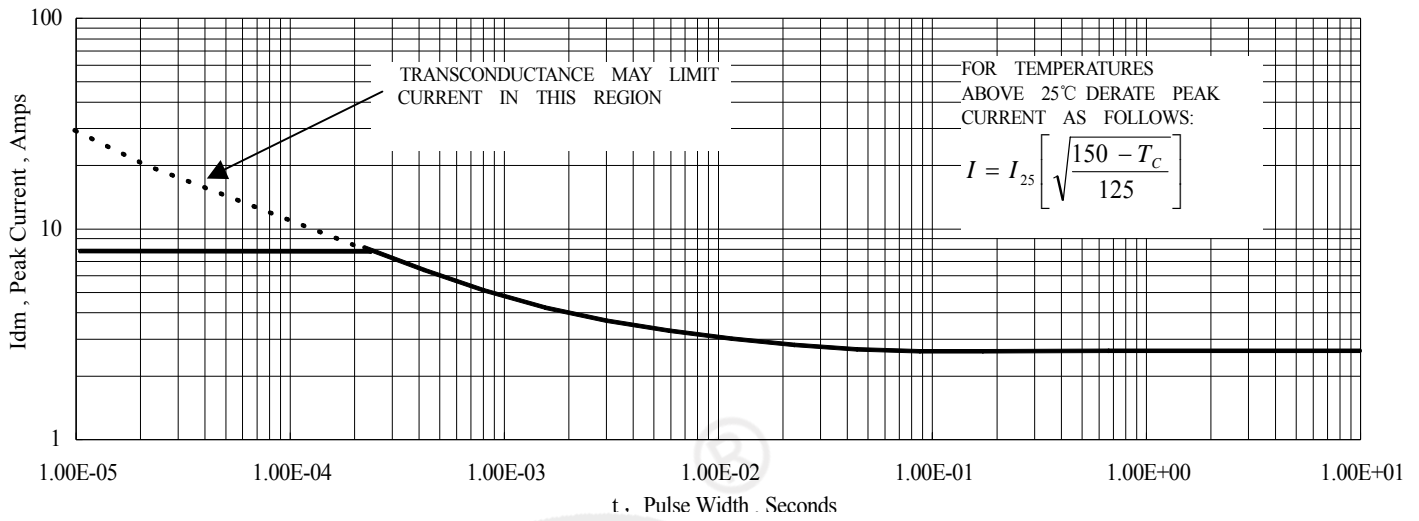

Figure 6 Maximum Peak Current Capability

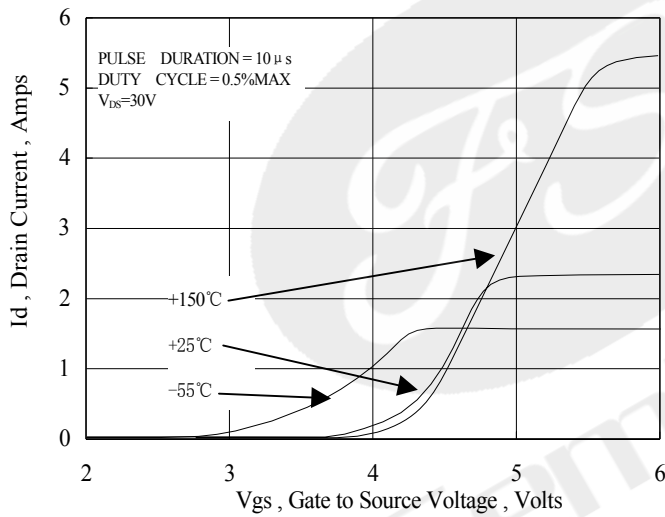

Figure 7 Typical Transfer Characteristics

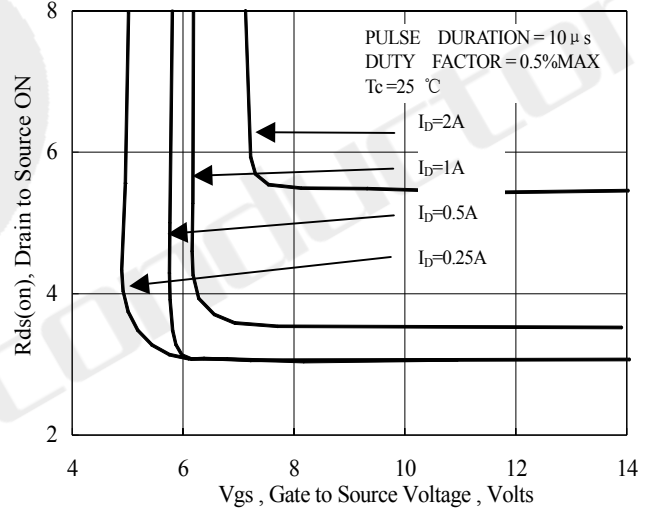

Figure 8 Typical Drain to Source ON Resistance vs Gate Voltage and Drain Current

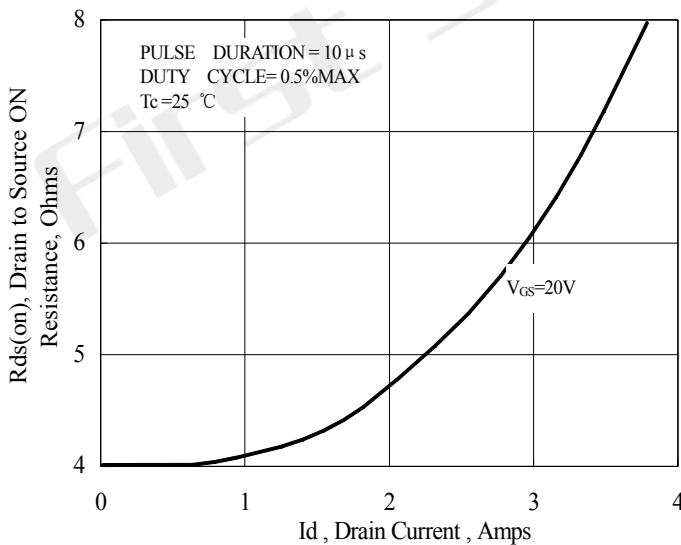

Figure 9 Typical Drain to Source ON Resistance vs Drain Current

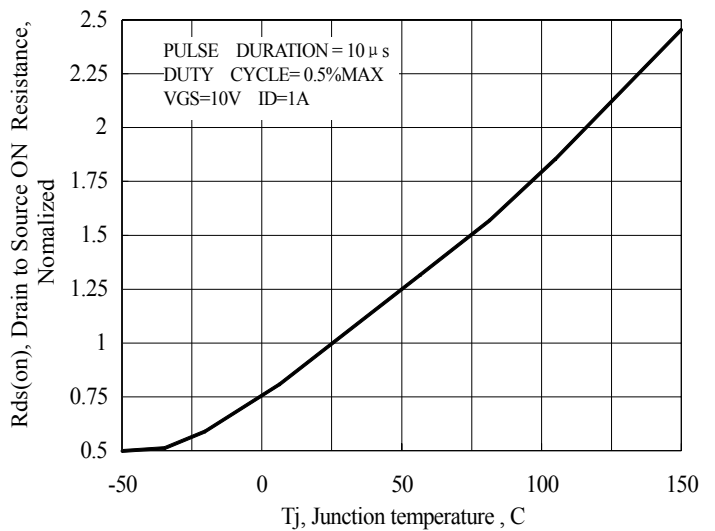

Figure 10 Typical Drain to Source on Resistance vs Junction Temperature

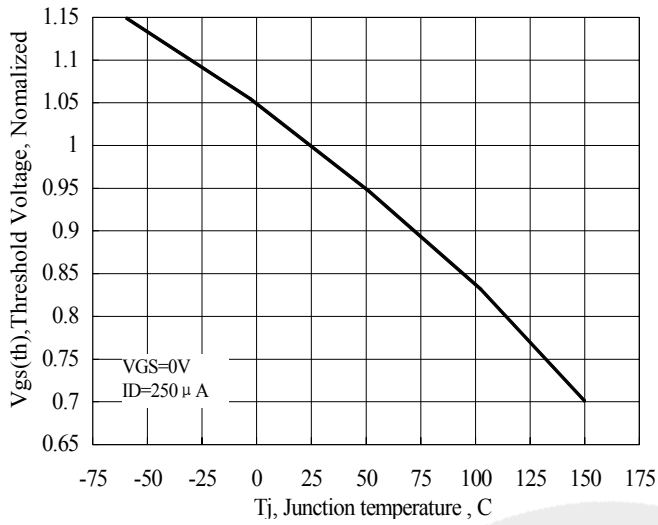

Figure 11 Typical Theshold Voltage vs Junction Temperature

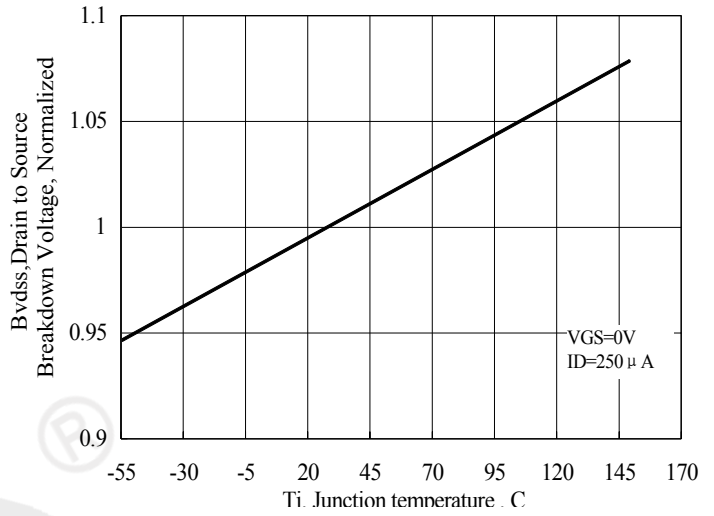

Figure 12 Typical Breakdown Voltage vs Junction Temperature

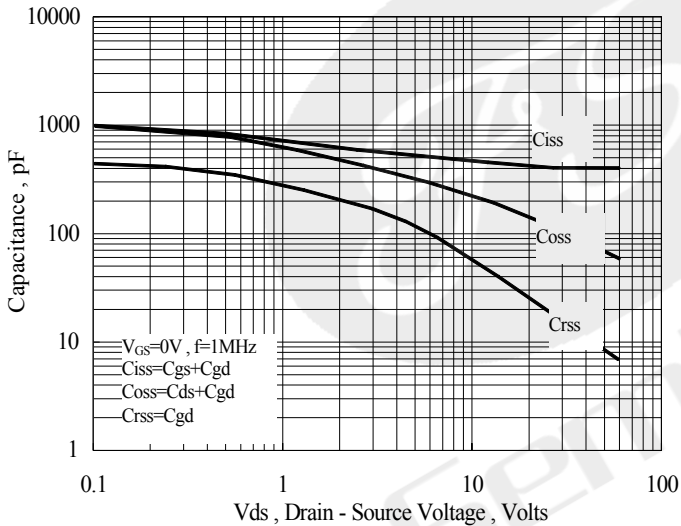

Figure 13 Typical Capacitance vs Drain to Source Voltage

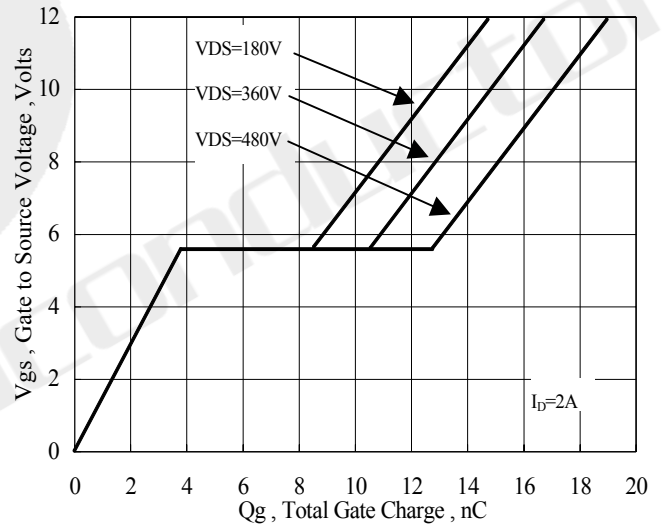

Figure 14 Typical Gate Charge vs Gate to Source Voltage

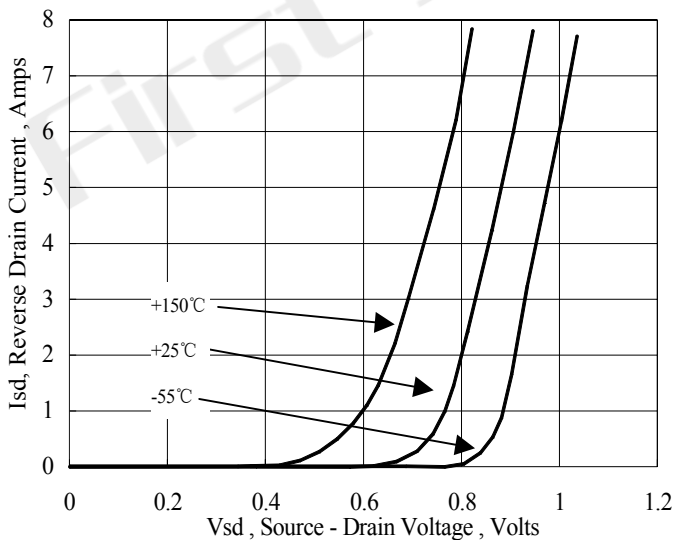

Figure 15 Typical Body Diode Transfer Characteristics

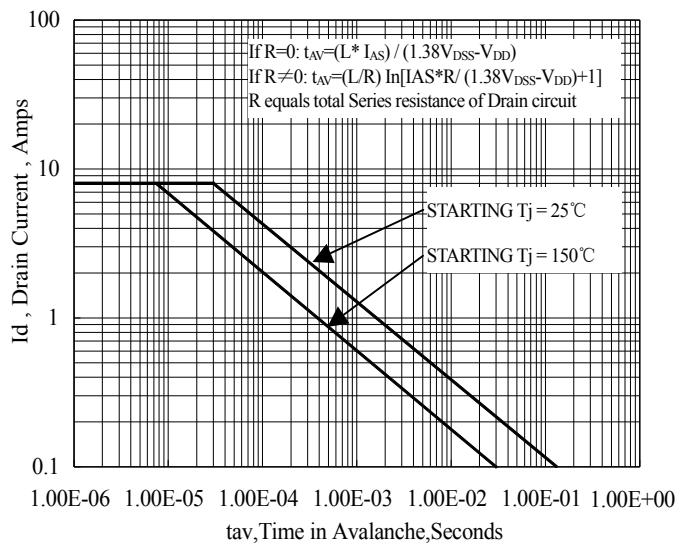
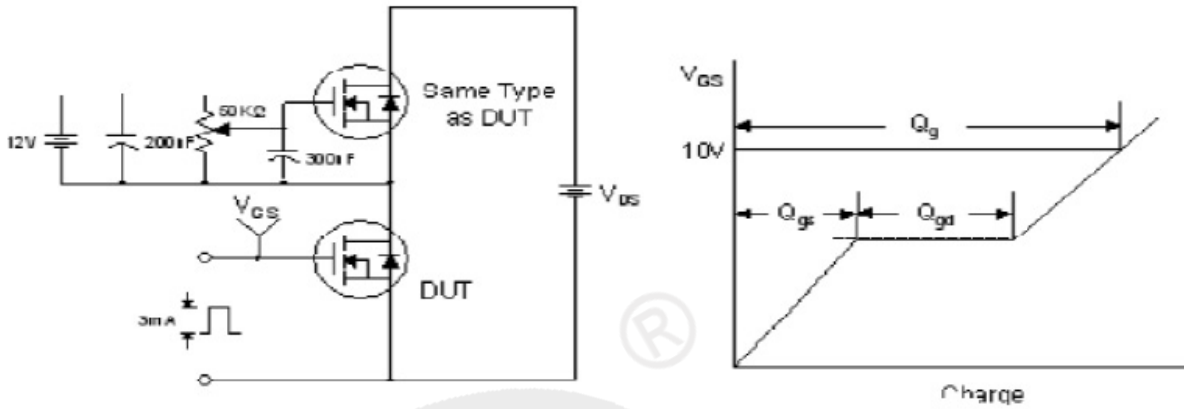
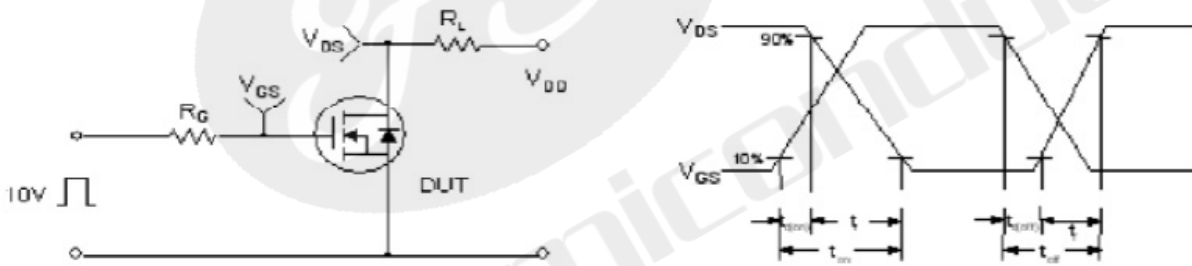

Figure 16 Unclamped Inductive Switching Capability

Test Circuit and Waveform



Gate Charge Test Circuit and Waveform



Resistive Switching Test Circuit and Waveform

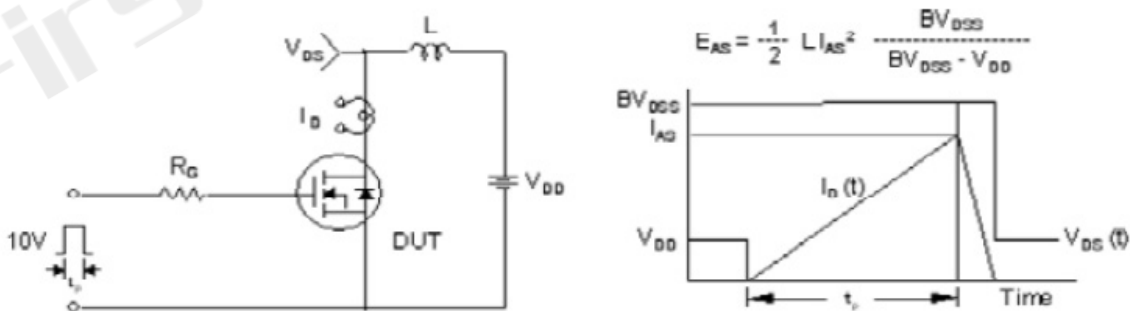

Unclamped Inductive Switching Test Circuit and Waveform

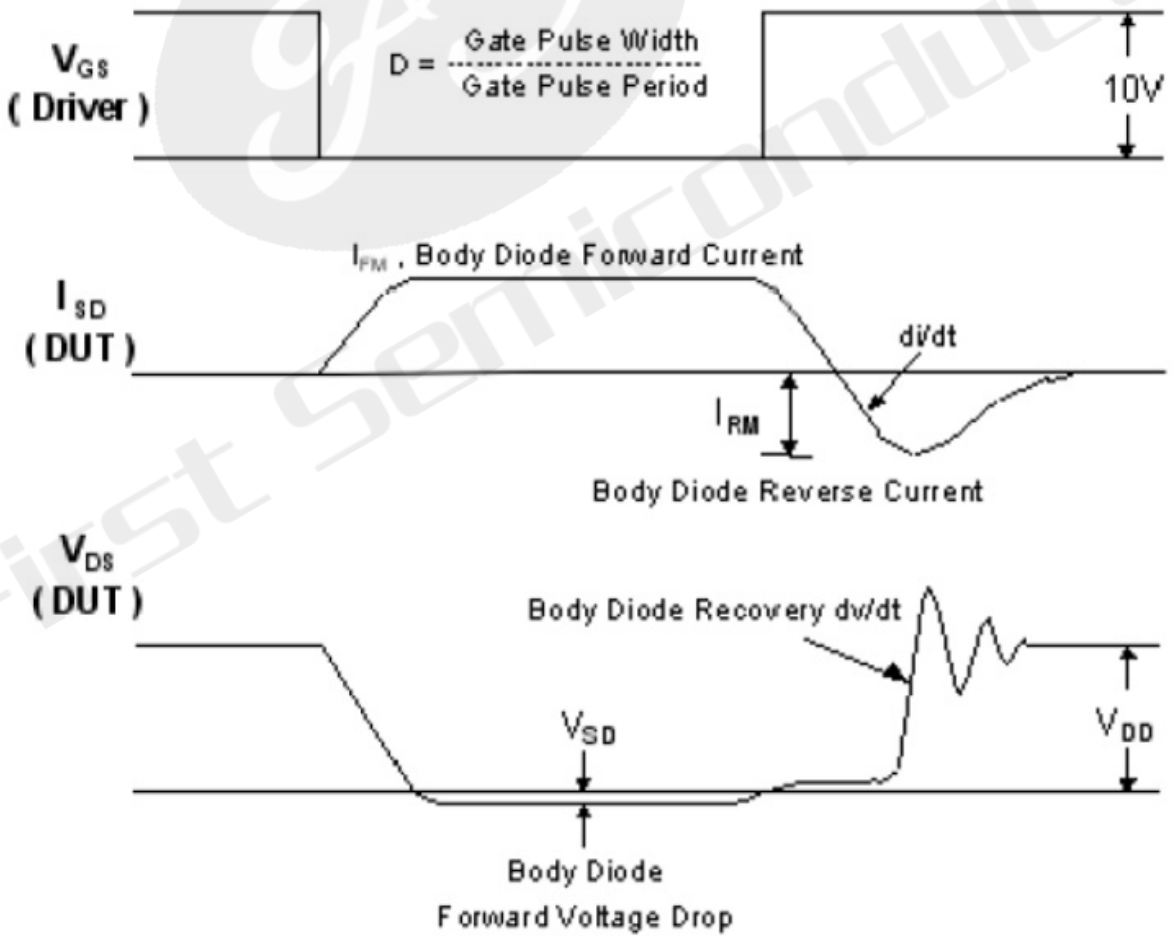
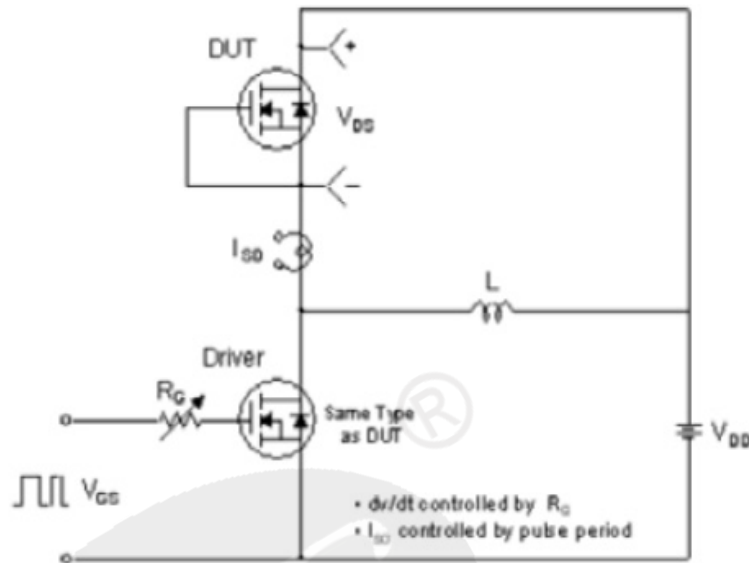

Diode Reverse Recovery Test Circuit and Waveform



Declaration

- FIRST reserves the right to change the specifications, the same specifications of products due to different packaging line mold, the size of the appearance will be slightly different, shipped in kind, without notice! Customers should obtain the latest version information before ordering, and verify whether the relevant information is complete and up-to-date.
- Any semiconductor product under certain conditions has the possibility of failure or failure, The buyer has the responsibility to comply with safety standards and take safety measures when using FIRST products for system design and manufacturing, To avoid To avoid potential failure risks, which may cause personal injury or property damage!
- Product promotion endless, our company will wholeheartedly provide customers with better products!

ATTACHMENT

Revision History

Date	REV	Description	Page
2018.01.01	1.0	Initial release	